

Thomas Young's theory of the arch. His analysis of Telford's design for an iron arch of 600 feet over the Thames in London

Santiago Huerta

The main lines of the development of arch theory are well known. The works of Poncelet (1852) and Winkler (1879) give a good review of the early theories from the XVIIth to the mid-XIXth century. Those theories refer to masonry arches (often called "rigid"). The theory of the "elastic" arch developed during the XIXth century and was applied first to iron and wooden arches; after the 1880's it was applied to any kind of arches. A detailed study of the history of the elastic theory may be found in Mairle (1933) and a good review of the fundamental lines in Hertwig (1941), Timoshenko (1953) and Charlton (1982). Heyman (1972, 1998) has studied the evolution of arch theory within the frame of limit analysis, and has placed it rigorously within the general frame of the modern theory of structures. A recent article by Kurrer (1997) covers both the history of rigid (masonry) and elastic theories. Finally, Foce (Becchi and Foce 2002) has contributed a new historical review and, more important, has compiled a comprehensive bibliography of the primary sources.

However, if the overall picture is clear, some details should still be investigated. Little parts of the canvas are still blurred and certain contributions, steps on the ladder of progress, have been forgotten. This is the case with the contribution of Thomas Young (1773–1829) to arch theory, which is not even mentioned in any of the works cited above. The omission is amply justified by Young's obscure prose and his eccentric way of publishing. His work, though considered important by some eminent contemporary engineers like Rennie, was not understood and rapidly forgotten. Young's arch theory exerted apparently no influence. But it is a fact that he had a deep understanding of arch behaviour (his theory was basi-

cally correct) and was well ahead from his contemporaries. The culmination of his work on arches is the article *Bridge* for the *Supplement* to the fourth edition of the Encyclopaedia Britannica, published in 1817. In it he exposed first the theory and then, as a tour de force, applied it to the analysis of Telford's unbuilt design for a great iron arch of 600 feet over the Thames (1800).

To put in context the work of Young a few words should be said about the state of the art of arch theory ca. 1800. Telford's design episode will be also revised because it served as a "touchstone" for the state of this theory in Britain and, also, because it could have triggered Young's interest in arch bridge design.

Arch theory circa 1800

At the beginning of the XIXth century there were two approaches to arch analysis: 1) the "equilibration theory", and, what we may call, 2) the "point of rupture" theory. The first originated and developed in Great Britain and the second in France. Both theories were considered essentially as different approaches until the 1840's when, thanks to the correct definition of the concept of "line of thrust" it was understood that both theories were equivalent.

Equilibration theory

The equilibration theory originated in Hooke's analogy (1675) between hanging chains and arches: "As hangs the flexible cable, so but inverted will stand the rigid arch". The statics of cables and arches is essentially the same, and the form of the catenary is the ideal form for an arch of uniform thickness. The architect or engineer following Hooke's approach would like to make the arch of the same form of the corresponding hanging chain. The matter was tackled mathematically by many English mathematicians and engineers during the XVIIIth century, and applied to arch analysis, for example, by Emerson (1754) and Hutton (1772, 1812). There were two basic problems: 1) to find the intrados for a given extrados; 2) to find the extrados for a given intrados, figure 1 (a) and (b).

In the case of a bridge, the load on the chain (the arch ring) was the weight of the arch plus the load of the filling and road. Being the last sensibly horizontal, the form of the arch should be such that the load in every point is proportional to the vertical distance of this point to an horizontal line of extrados. In 1801 Robison proposed a hanging model, figure 1 (c), with rods representing the load, which expressed clearly the philosophy of bridge design following the equilibration theory. The physical interpretation of the equilibration arch is a series of smooth voussoirs with the joints always normal to the curve of intrados. Both approaches lead to the same result: a certain fixed form (the intrados) for the transmission of the thrusts, the curve of equilibrium. The theory gives no information

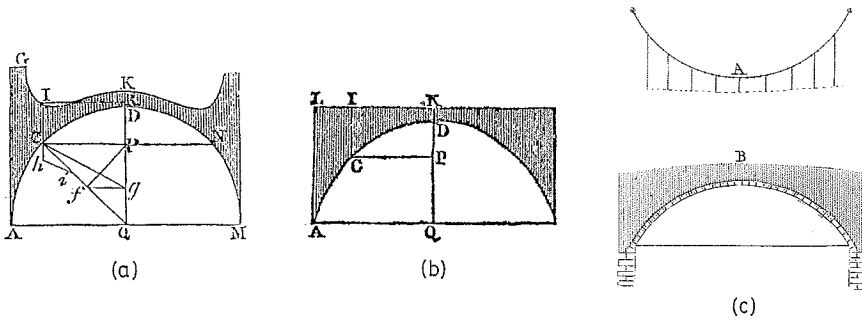

Figure 1

The two main problems of the equilibration theory: (a) To find the curve of extrados for a given intrados; and (b) to find the form of a intrados for a given extrados. (Hutton 1812). In figure (c) the model suggested by Robison in 1801 to solve the second case (Young 1807)

about the thickness of the arch and does not explain common phenomena as the cracking of arches. Of course, the equilibration theory permits to calculate the thrust of the arch, which is the reaction at the end of the inverted chain, known in position, magnitude and direction. However most English contributions did not tackle the problem of buttress.

The problem is that any change of the load will distort the curve of equilibrium, which will fit no longer with the built arch (and Robison's model may be used to check this assertion experimentally). The case is specially serious in bridge design, a bridge being precisely an structure for the passing of moving loads. Besides, the curves obtained were difficult to construct with simple geometrical methods, and therefore not adequate for the common practice of building. However, these inconvenients did not deter engineers and mathematicians who continued to expend a lot of labour and ingenuity in studying every conceivable situation for arches, first, and then for domes and vaults.

“Point of rupture” theory

The second theory originated in France and La Hire (1712) made the first contribution. The approach is not directed to the study of the form of the arch but to obtain its thrust in order to calculate the depth of the abutments. La Hire observes that in a collapsed arch or barrel vault the inferior part remains united to the abutment, marking the “point of rupture” of the arch or barrel vault. The thrust must pass through this point and be tangent to the intrados and, once locat-

ed the points of rupture, the calculation of the thrust follows easily establishing the equilibrium of the upper part. La Hire's theory was modified by Bélidor (1729) who fixed the position of the point of rupture half way between the crown and the springings, and displaced the thrust to the middle of the joint. This modification was interpreted "physically" as a non-friction theory, the thrust resulting from the weight of the upper part acting as "wedge" without friction against the planes of joint. But, the objective remained the calculation of the thrust in order to design the abutment. Bélidor's method, though incorrect, gave buttress depths which agreed well with the experience and was almost universally accepted in the continent.

The essays of Danyzy (1732) demonstrated the impossibility of sliding and the formation of hinges between the stones. Apparently without knowing them, Couplet (1730) developed the first arch theory considering friction which was completed by Coulomb (1773) who explained the method to be followed (employing the method of maxima and minima) to locate correctly the position of the joint of rupture. Coulomb's memoir was forgotten for almost fifty years, until Audoy (1820) resolved the equations for the most usual profiles of arches. Then, Audoy calculated the abutments and realized, with comparison with the usual measures, the necessity of increasing the calculated thrust to obtain an adequate degree of safety.

In conclusion, the "French theory" was concerned primarily with the determination of the point of rupture (defining the collapse mechanism, the other two hinges located in the crown and in the springings) in order to calculate the thrust against the abutments for an arch of a given form, and was not concerned either with the design of the arch or with the internal forces in the arch.

"Line of thrust" theory

Apparently the equilibration theory and the point of rupture theory were completely different. A new idea was needed to obtain a complete understanding of arch behaviour: this is the concept of "line of thrust", which appeared almost simultaneously in England (Moseley 1835, 1838) and France (Méry 1840). The line of thrust is the locus of the point of application of the thrusts (internal forces or stress resultants) for a given family of joints. The thrusts need not be normal to the joints (they only should be contained within the friction cone) and the drawing of the line permits to check the main statement about the material: masonry must work in compression and hence the line of thrust must be contained within the arch. Both Moseley and Méry related the lines of thrust with the formation of collapse mechanisms, comparing their analysis with the results of the collapse experiments of Boistard (1810), and the observations of Gauthey (1809). The concept, then, results in a fusion of the two theories. The approach produced an

enormous advance in the understanding of arch design and analysis. For example, the study of lines of thrust made "evident", not only the existence of two limits for the value of the horizontal thrust of a line contained within the arch (already predicted by Coulomb), but, also, and this was crucial, that between these two extreme situations an infinite number of lines of thrust may be drawn within the arch. The indeterminacy of the position of the line of thrust "tortured" engineers during the whole second half of the XIXth century and the solution only came with the Fundamental Theorems of Limit Analysis (Heyman 1995). From the practical side, the concept of line of thrust leads easily to graphical statics (equilibrium analysis) and supplied architects and engineers with a simple tool for the practical calculations of arches of any form under any system of loads of arches.

Then, the "line of thrust theory" emerges almost without warning, with a remarkable degree of perfection. It is not an uncommon phenomenon in the history of science or applied science: the time was ripe for a new discovery. However, looking at the painful development of arch theory during the XVIIIth century, some kind of transition would have been expected. This paper will show that some 20 years before Moseley and Méry, Thomas Young not only had the idea of line of thrust and applied it correctly to symmetrical arches, but that he used it, also to study the stability of arches under unsymmetrical loads, and made a completely correct analysis of some "real" arch bridges, an analysis that will be accepted today as completely correct.

Improvements in the Port of London: Telford's design of an iron arch of 600 feet span

In the history of the theory of structures it is not uncommon that certain episodes have led to expertises which have marked a turning point in the development of the theory. This was the case in 1742 when Pope Benedict XIV asked for expertises to elucidate the safety of Saint Peter's dome. The reports written by Poleni and the three mathematicians (Jacquier, Le Seur and Boscovich) marked a turning point in the analysis of real domes (Straub 1952). In other cases, the problem proved too difficult and the expertises served mainly to call the attention to the insufficient development of the theory, and can trigger new theoretical developments. This was the case with the discussions relating the design of the pillars and dome of Sainte-Geneviève, today the French Pantheon. This was also the case with Telford's design for an iron arch of 600 feet (183 m) over the Thames in 1800. The story has already been exposed in detail by Dorn (1970), Ruddock (1979) and Skempton (1980), and will be summarized briefly in the following lines.

In the 1790's the growth of trade made necessary a large reform of the Port of London. In the years 1798 and 1799 several proposals were made to replace the old London Bridge in order to admit the passage of cargo ships. All the proposals were influenced by the success of the iron bridge built at Sunderland in 1796 with a span of 236 feet (72 m); this was a proof of the feasibility of using cast iron in the building of large bridge arches. The Select Committee formed to study the reform advertised for designs for a new bridge with 65 feet height above high water, suitable for passage of 200 ton ships. Several designs were presented: Thomas Wilson (an iron bridge of three arches, 220, 240 and 220 feet span), Ralph Dodd (a monumental masonry bridge) and Telford and Douglass (three designs of three and five iron arches). George Dance proposed a draw-bridge. All the projects were prepared for publication in the Third Report of the Select Committee of 28th July 1800.

Then a report by William Jessop attracted the attention of the Committee. Jessop argued that to allow the passage of cargo ships the river should be dredged from the actual deep of 6 to 10 feet to 13 feet in the middle and that to maintain the velocity of water the river should be narrowed to 600 feet, constructing embankments and warves (Ruddock 1979, 156). The reduction to the span to 600 feet prompted Telford and Douglass (though the design of the bridge must be attributed to Telford¹) to present in the autumn of 1800 a new project with a single cast-iron arch covering the whole span. The design arrived too late to be included in the Third Report, but a plate with the plan and elevation (Fig. 2) and a report and estimates were issued in a Supplemental Appendix. A model of the bridge was also made. The Committee expressed his admiration for the new design:

The obvious advantages which would be obtained if the Communications could be effected by Means of Single Arch, as well as the Magnificence of the proposed Structure, appeared to give the . . . Design a particular Claim to the Notice of Your Committee; yet the Attempt was of so novel a Nature, that they thought it absolutely necessary for their own Information, as well as for the Purpose of affording some Grounds upon which the House might hereafter form their Judgement as to its Expediency, to request the Opinions of some of the Persons most eminent in Great Britain for their theoretic as well as Practical Knowledge of such Subjects. (Fourth Report 1801)

The Committee draw up twenty-one questions to be sent with the design and two additional explanatory drawings of the framing of the ironwork (Fig. 3) to a list of eminent experts.² The experts selected included three groups of persons: scientists and mathematicians, eminent engineers and iron makers. The strategy of the Committee was to seek the correct answers combining the judgements of

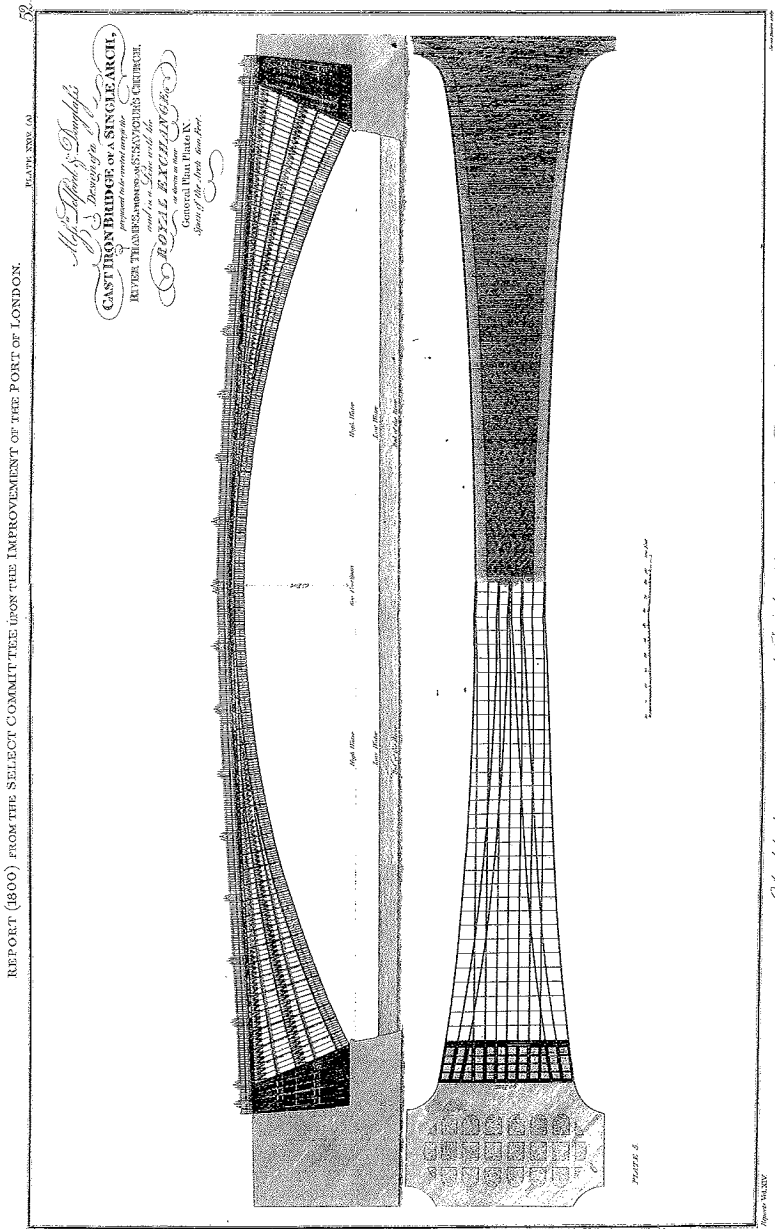

Figure 2
Plan and elevation of Telford's design of 1800 for an iron arch bridge of 600 feet to be built over the Thames in London. (Third Report 1800)

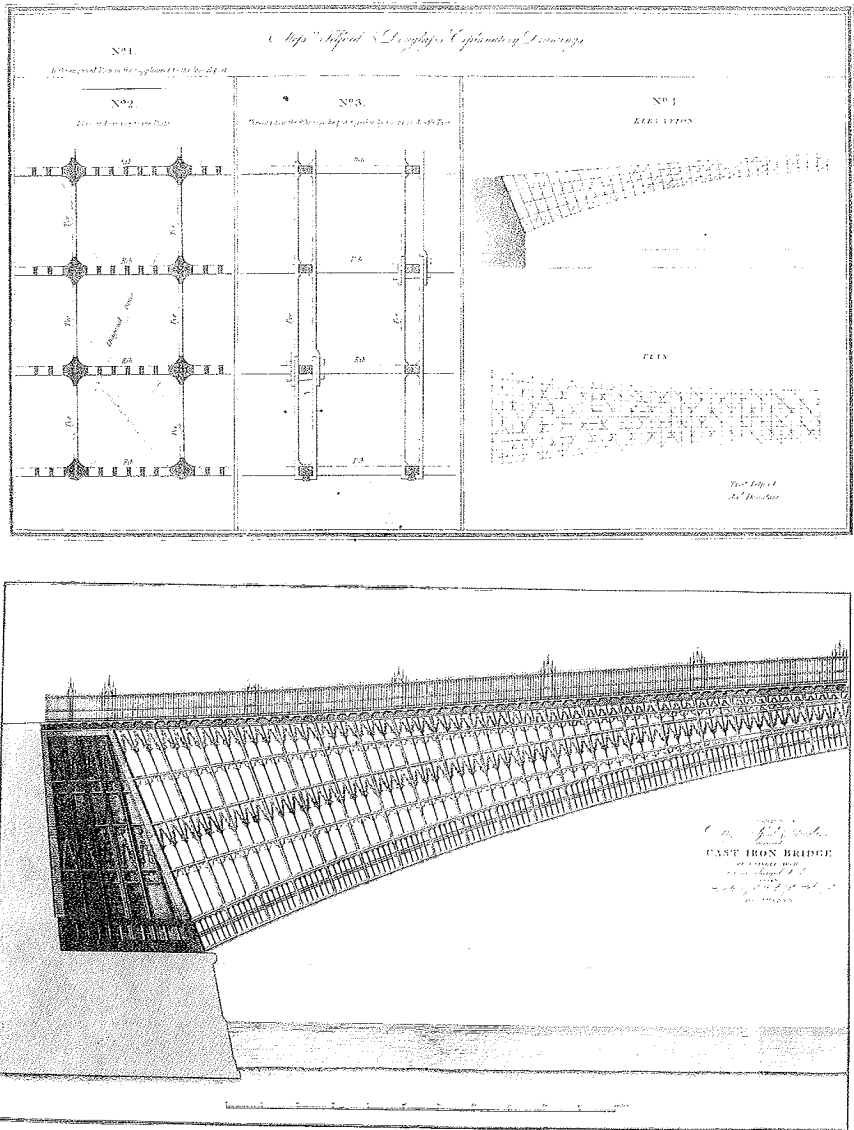

Figure 3
Explanatory drawings of Telford's design. "Plan of framing shewing how the ribs may be put together". (Fourth Report 1801)

all these approaches. In fact, it was Telford himself who drafted the questions while corresponding with several of the selected experts. It is obvious that he dedicated a lot of attention to the matter (he made four drafts) and the list constitutes an exhaustive questionnaire in which all the matters relating to the design of a bridge are considered (the list is reproduced in an Appendix at the end of this paper). The questions were sent early in April 1801 and nearly all replies were dated at the end of this month. The questions and answers, together with the new drawings, were issued in the Fourth Report on 3rd June 1801.

The answers received must have supposed a great deception both to the Committee and to Telford himself. There is no space here to enter in detail in the matter (for a discussion see Dorn 1970; brief comments in Skempton 1980) but it was evident that the state of knowledge of structural theory was insufficient to answer the precise and intelligent questions posed by Telford. Quoting Peacock (1855, 422): "The answers which were given were singularly humiliating to the pride of philosophy: they were not only altogether at variance with each other, but in very instance incomplete and unsatisfactory".

Telford pressed forward in favour of his design and in the summer of 1801 an splendid engraving with a large view of the design was published, which attracted a lot of attention from the public. The same year, he published, also, an article in the prestigious *Philosophical Magazine*. Still a year later Telford apparently have received notes of congratulation from the King (Ruddock 1979), but the proposal was finally abandoned and eventually the new London Bridge was built as a traditional masonry bridge of three arches. This must have been an enormous deception to Telford and maybe a sign of this is that no mention is made of this episode in his autobiography (Rickman 1838).

The reasons for the abandon of such a magnificent design were not made explicit. It is a fact that most of the experts have a favourable opinion as to feasibility of the design, Question XX of the list, though they were unable to justify it. Both Ruddock and Skempton believe that the main reason would have been the cost and complexity of building the long approaches to the bridge. However Dorn (1970), though considering also the economical aspect, says that "a suspicion lingers that the project was undermined by the inability of the Committee's respondents to provide any convincing assurance that practice harmonised with theory in Telford's majestic design". Indeed, the questions were so clear and straightforward that the inability to be answered would have caused suspicion in any cultivated man.

The whole episode provoked an awakening in the interest in arch theory in Britain. Some of the respondents published articles and books on the subject. Hutton urged to make a reprint on 1801 of his treatise on bridges of 1772 and in his *Tracts* of 1812 included a new improved and revised edition of it. Southern

(1801) published a paper on the equilibrium of arches. The same year Atwood published *A Dissertation on the construction and properties of arches*, which was followed in 1804 by a *Supplement*. In 1811 an anonymous correspondent published in the *Philosophical Magazine* a paper with the expressive title "Some Account of the different Theories of Arches or Vaults, and of Domes, and of the Authors who have written on this most delicate and important Application of Mathematical Science" (Some Account 1811). In this paper, maybe for the first time in England, a detailed account of the French theories of arches is given. However, none of these contributions supposed a remarkable advance on the state of the theory which would have permitted to answer the 21 questions posed by Telford on bridge analysis and design.

Thomas Young's theory of the arch

Against this background should we see Thomas Young's contribution to arch theory. He was interested in arch theory for a period of fifteen years, between 1801 when he accepted to deliver the Lectures for the Royal Institution (this marks the beginning of his interest on the Mechanical Arts), and 1816 when he finished writing his article "Bridge" published the next year in the *Supplement to the fourth edition of the Encyclopaedia Britannica*. A study of the evolution of Young's studies on arches, though concentrated only in two publications, the *Lectures* of 1807 and an obscure paper "On the structure of covered ways", published anonymously in 1807, will require more space than is allowed in the present book. Therefore we will concentrate in the article "Bridge" which contains his whole theory on arches.³

The article was included by Peacock (1855) in his edition of the *Miscellaneous works of the late Thomas Young*, but with some important modifications. First, he reduced considerably the number of figures; only the first 7 figures of the first of the three plates of the original article were included, which form the upper part of the first original Plate reproduced in figure 4. Secondly, he eliminated the comments of the figures included. And, finally, the sixth and last section of the article was completely suppressed. Particularly, this last suppression makes difficult to understand some of Young's propositions which were applied in this section to the analysis of the bridges of Southwark and Waterloo. However, as it is much easier to consult Peacock's edition (which, besides, has been reprinted in 2003) than the original article in the *Encyclopaedia*, in what follows all the references within brackets are to the pages in the *Miscellaneous works*, except when otherwise specified.

Young is very explicit about his intentions, and the article begins:

BRIDGE.

PLATE XIII.

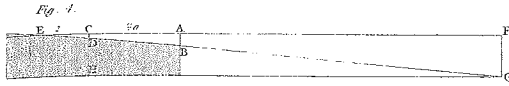
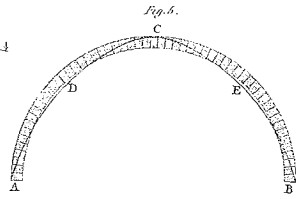
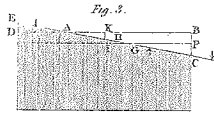
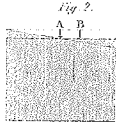
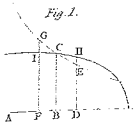
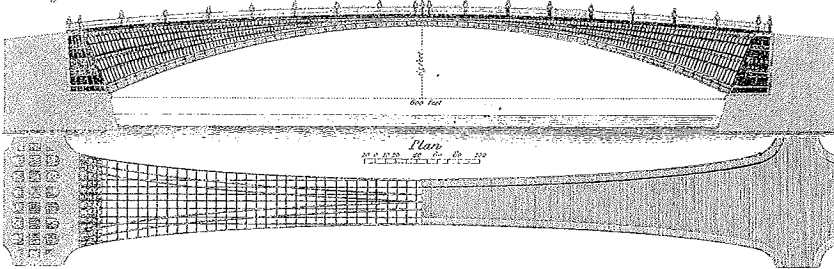

Fig. 6.



BRIDGE PROPOSED BY MESS: TELFORD AND DOUGLASS.

Fig. 7.



COLEBROOK DALE

Fig. 8.

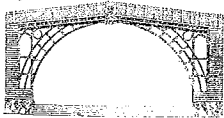

WEARMOUTH

Fig. 9.

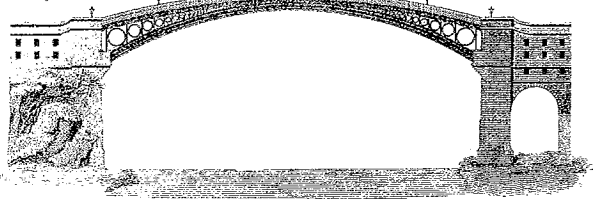

Fig. 10.

BUILDWICKS



Fig. 11.

PONTYSSILVE



Fig. 12.

BRISTOL



Published by A. Constable & Co. Edin: 1817.

Engraved by Edm: Barrell.

Figure 4
First Plate of the article "Bridge" written by Thomas Young for the Supplement to the 4th Edition of the Encyclopaedia Britannica. (Young 1824 [1817])

The mathematical theory of the structure of bridges has been a favourite subject with mechanical philosophers; it gives scope to some of the most refined and elegant applications of science to practical utility; and at the same time that its progressive improvement exhibits an example of the very slow steps by which speculation has sometimes followed execution, it enables us to look forwards with perfect confidence to that more desirable state of human knowledge, in which the calculations of the mathematician are authorised to direct the operations of the artificer with security, instead of watching with servility the progress of his labours. (194)

The criticism to the actual situation of impotence of the theory to explain the normal practical procedures or to check the feasibility of new designs is clearly stated, and so it is the ambitious objective of formulating a theory which could put an end to this state of affairs, harmonising theory and practice.

The article is divided in six parts. The first three contains the theory of arches: 1) "Resistance of materials", 2) "The equilibrium of arches" and 3) "The effects of friction". The fourth part contains some "Earlier historical details" (a discussion on the origin of the arch and a review of "the most important operations" in bridge building, extracted from Smeaton Reports). The fifth part contains "An account of the discussions which have taken place respecting the improvement of the port of London". In fact, this part is dedicated to answer in detail to the 21 questions of the Select Committee, applying the theory previously exposed in the first three parts. Finally the sixth part is "A description of some of the most remarkable bridges which have been erected in modern times". In this part, after a brief history of the iron bridges, the theory of arches is applied to analyze in detail the bridges of Southwark and Waterloo. In all, of the 23 pages of the article, 19 pages are dedicated to strictly structural matters.

Resistance of materials

In this part Young particularize his theory of "passive strength" already expounded in his *Lectures* of 1807 with a view to its application to arches. Young makes an effort to explain the theory in rigorous terms. The method used by Young is the "classical" method of stating a proposition (named alphabetically from A to Z) and then demonstrating it. This way of exposition makes difficult to follow the general line of reasoning and results particularly exasperating to a modern reader. The propositions though formulated in a general manner are directed to study the arch problem: a curved structure functioning mainly in compression.

First he states the proportionality between tensions and deformations and to justify this he expounds a theory of cohesive and repulsive molecular forces and states that even if the law of this forces is not linear (*fig. 1* in figure 5), the effect will be proportional for a small "change of dimensions". (196)

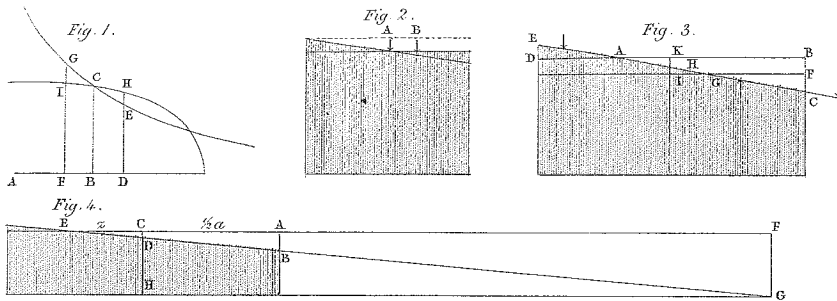

Figure 5

Drawings on "Resistance of materials". Young is concerned with the "compression" or "extension" of a joint which remains plane after deformation. He treats deformations not stresses. (Detail of Figure 4 above)

He then treats the eccentric compression of a block and states and begins considering the limit position of an eccentric force so that all the section remains in compression and the corresponding increase in the stresses. However, the way he expressed the problem is as follows: "The strength of block or beam must be reduced to one half, before its cohesive and repulsive forces can both be called into action". A modern engineer may have no difficulty in interpreting this: Young is obviously referring to the "middle third" concept and the maximum stress is double as the mean stress. To demonstrate this, Young assumes explicitly that plane sections remain plane after the deformation. It follows that the deformations (compressions or extensions) varies linearly and "consequently the forces may always be represented, like the pressure of a fluid, at different depths, by the ordinates of a triangle; and their result may be considered as concentrated in the centre of gravity of the triangle, or of such of its portions as are contained within the depth of the substance." (197) Here Young is struggling with the concept of stress and he uses the analogy of the pressure of a fluid. However he tries always to speak in terms of deformations, the "forces" or "pressures" being always proportional to them, as stated in the first proposition, and not of stresses (*fig. 2* in figure 5).

The next proposition states that "the compression or the extension of the axis of the block or beam is always proportional to the force, reduced to the direction of the axis, at whatever distance it may be applied". (198) The deformation of the axis is always equal to the mean deformation, produced by the normal component of the force applied in the middle of the section. The transverse component of the force will be resisted by "lateral adhesion" (shear) and if the force is normal to the axis "the length of the axis will remain unaltered".

Then Young proceeds to locate the neutral point for this general force placed at any distance: “The distance of the neutral point from the axis is to the depth, as the depth to twelve times the distance of the force, measured in the transverse section”. In an algebraical form

$$z = \frac{a^2}{12y} \tag{1}$$

where z is the distance of the neutral point from the axis, a is the depth of the section and y is the distance of the point of application of the force to the axis. Young’s demonstration is based in the proportionality of the stress resultants and the triangular form of the stress blocks; it is not easy to follow even knowing that it is correct.

The next proposition tries to relate the increase of the normal stresses in terms of the distance of the force from the axis: “The power of a given force to crush a block, is increased by its removal from the axis, supposing its direction unaltered, in the same proportion as the depth of the block is increased by the addition of six times the distance of the point of application of the force, measured in the

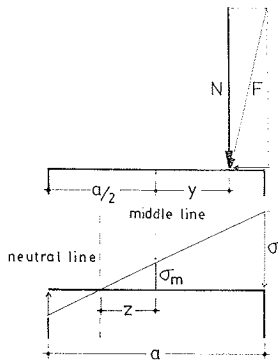

Influence of the position of the thrust:

location of the neutral line:

$$z = \frac{a^2}{12y}$$

increase of the stress:

$$\sigma = \sigma_m \left(\frac{a + 6y}{a} \right)$$

where

$$\sigma_m = \frac{N}{a} \text{ (per unit breadth)}$$

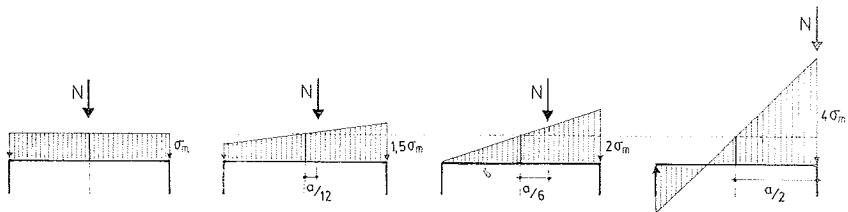

Figure 6

Young’s propositions on “Resistance of materials” expressed in modern terms (stresses).

transverse section". (199) Young is referring to the increase of the stresses due to the eccentricity of the load. In modern terms, if we call σ_m the mean compressive stress produced by the force applied in the center of the section, the removal of the force at a distance y will produce a stress σ given by

$$\sigma = \sigma_m \left(\frac{a + 6y}{a} \right) \quad (2)$$

Young demonstrates the assertion, again, for similar triangles (*fig. 3* in figure 5). Therefore, now we are in the situation to ascertain the "strength" (stress distribution) of any section acted by any force located at any distance, figure 6.

On the equilibrium of arches

The next Section of the article treats the equilibrium of arches, i.e. it is an study of the definition and mathematical properties of the curves of equilibrium (lines of thrust), but with a view to their application in the analysis and design of actual bridges.

DEFINITION OF LINE OF THRUST: To study the equilibrium of arches Young "proceed to inquire into the mode of determining the situation and properties of the curve of equilibrium, which represents, for every part of a system of bodies supporting each other, the general direction of their mutual pressure". (204) Here is, twenty years before the official date of 1835, the definition of line of thrust. Young has liberated himself from the straitjacket of the equilibration theory (vertical loads, thrust following the line of intrados) and speaks freely of the equilibrium of a system of bodies in contact.⁴

Young is well aware that the form of the curve of equilibrium (in what follows we will use this term) depends on the family of planes of joint considered: ". . . it is obvious that the forces . . . may vary very sensibly in their proportion if we consider the joint operation on a vertical or on an oblique plane". (205) However, he immediately remarks that ". . . if the depth of the substance be inconsiderable, this difference will be wholly imperceptible, and in practice it may generally be neglected without inconvenience; calculating the curve upon the supposition of a series of joints in a vertical direction". (205)

He explains, however, the method to study any particular joint: "if we wish to be very accurate, we must attend to the actual direction of the joints in the determination of the curve, and must consider, in the case of a bridge, the whole weight of the structure terminated by a given arch stone, with the materials which it supports, as determining the direction of the curve of equilibrium where it meets the given joint . . . this consideration being as necessary for *determining the circumstances under which the joints will open, as for the more*

imaginary possibility of the stones sliding upwards or downwards". (italics are mine)

Young, then, has a perfect grasp of the concept of line of thrust but, instead of losing himself in the mathematical intricacies of the problem (considering different families of planes of joint); he considers a good approximation the assumption of vertical joints, but bearing in mind the possibility of studying in more detail any particular joint.

Then Young formulates a series of propositions addressed to apply his ideas of curves of equilibrium to different types of loads.

CURVE OF EQUILIBRIUM IN A FLAT ARCH: He begins with the straight arch, the platebande, and deduces that the form of the curve of equilibrium must be parabolic. Young uses this simple example of the platebande to make clear his ideas of the curve of equilibrium. He remarks that the thrust in the central joint must be horizontal and, then, chooses a system of vertical joints "which is the only way in which we can easily obtain a regular result". (206) For a block cut at distance x from the middle, calling the ordinates y , as the weight is proportional to x , it is evident that $x = m \frac{dy}{dx}$, and integrating, $(1/2)x^2 = my$, which is the equation of a parabola. Now Young alludes to the conventional representation of this line as an inverted funicular polygon (as we call it nowadays): "It is usual in such cases to consider the thrusts, rectilinear throughout, and as meeting in the vertical line passing through the centre of gravity of each block; but this mode of representation is evidently only a convenient compendium".

GENERAL EQUATION OF THE CURVE OF EQUILIBRIUM: In the next proposition Young gives the general equation of the curve of equilibrium for any symmetrical vertical distribution of the load, considering vertical joints: "In every structure supported by abutments, the tangent of the inclination of the curve of equilibrium to the horizon is proportional to the weight of the parts interposed between the given point and the middle of the structure". (207) He notices that in bridges the loads may not act entirely in a vertical way, some materials exerting a lateral pressure also; due to the symmetry, this does not affect the general truth of the assertion, though the form of the curve of equilibrium will vary slightly. He discourages the use of such materials for the filling.

Then, we have:

$$\int w dx = mt = \frac{dy}{dx} \quad (3)$$



Figura 7
Line of thrust or curve of equilibrium for a symmetrical arch, which supports a vertical load, considering vertical joints.

where “ w is the height of uniform matter, pressing on the arch at the horizontal distance x from the vertex, t is the tangent of the inclination of the curve of equilibrium (\tan), y is the vertical ordinate, and m is a quantity proportional to the lateral thrust, or horizontal thrust”. If we consider a vertical load, m is equal to the horizontal thrust, figure 7.

Young now studies the properties of curvature of the curve of equilibrium in relation with the load and the inclination of the thrust and extracts two corollaries relating to circular and parabolic curves of equilibrium: “The radius of curvature of the curve of equilibrium is inversely as the load on each part, and directly as the cube of the secant of the angle of inclination to the horizon”. (208)

The general expression of the radius of curvature is,

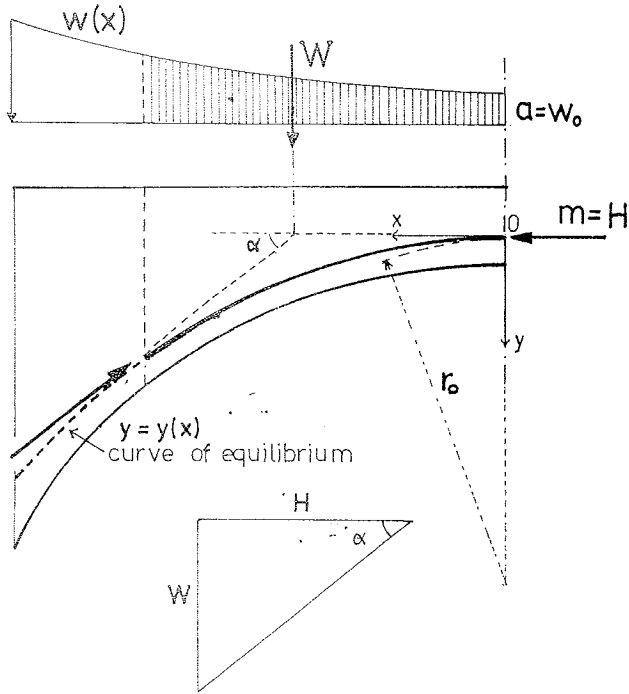
$$r = \frac{(dz)^3}{dx d^2 y}$$

where dz is a differential element of the curve (following Young's notation). But $mdy = \int w dx$ and it follows $m d^2y = w(dx)^2$; $dz = dx \sqrt{1 + t^2}$, and substituting in the above equation of the radius,

$$r = \frac{m}{w} (1 + t^2)^{\frac{3}{2}} = \frac{m}{w} (1 + (\tan \alpha)^2)^{\frac{3}{2}} = \frac{m}{w} (\sec \alpha)^3 \quad (4)$$

and at the crown, $\sec \alpha = 1$, $w = w_0$

$$r_0 = \frac{m}{w_0} \quad (5)$$

HORIZONTAL EXTRADOS AND INTRADOS TERMINATED WITH THE CURVE OF EQUILIBRIUM: This was the usual assumption for bridges in many previous arch treatises. He expresses the result in the form of a proposition: "For a horizontal extrados, and an intrados terminated by the curve itself, which, however, is a supposition merely theoretical, the equation of the curve is

$$x = \sqrt{m} \ln \left(\frac{y + \sqrt{y^2 - a^2}}{a} \right), \quad (6)$$

In this case the load $w = y$ and, for a depth of the arch a at the keystone, Young obtains the equation of the abscissas in function of the ordinates because the integration is much more easy. The result is correct and obviously to obtain the different points of the curve for different ordinates only a table of neperian logarithms is needed. However, Young makes clear that "such a calculation is by no means so immediately applicable to practice, as has generally been sup-

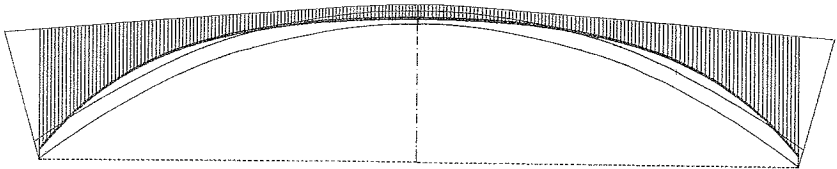

Figure 8

Curve of equilibrium for a load which is proportional to the vertical distance to a horizontal extrados. In a "typical" arch, maybe of circular form, if the curve pass through the middle of the joints at the keystone and abutments (Young's usual assumption), the curve lies completely outside of ring of normal thickness.

posed; for the curve of equilibrium will always be so distant from the intrados at the abutments, as to derange the whole distribution of the forces concerned". (209) In fact, this approach contradicts the main objective of Young, which is to free the curve of equilibrium from the "straitjacket" of the intrados. Besides, if we obtain this curve, passing through the middle of the joints at the crown and the springings (Young's usual assumption), the form of the curve of equilibrium differs so much from that of the arch as to be completely useless, figure 8.

PARABOLIC LOAD: This is the most important proposition of this part. Young realizes that to handle in a convenient way the different curves for a given load, this load should have a mathematical definition which leads to a simple integration. Also, it should be sufficiently flexible to adapt to the real loads in a bridge and to take into account the inclination of the joints, if considered necessary. He decides that a parabolic load fulfils both conditions and gives the corresponding equation : "If the load on each point of an arch be expressed by the equation $w = a + bx$, the equation for the curve of equilibrium will be

$$my = \frac{1}{2} ax^2 + \frac{1}{12} bx^4". \quad (7)$$

The whole load $W = \int w dx = ax + (1/3)bx^3$. Now, $m (dy/dx) = ax + (1/3)bx^3$, and integrating the above cited expression is obtained. Young cites explicitly its advantages: "This expression will, in general, be found sufficiently accurate for calculating the form of the curve of equilibrium in practical cases; and it may easily be made to comprehend the increase of the load from the obliquity of the arch-stones". (210)

Given the ordinate y at the abutments (that is the height of the curve of equilibrium between its springings and the point of horizontal tangent at the joint of the keystone) it is easy to obtain the value of the horizontal thrust m . And at the keystone $w = a$ and the radius of curvature is $r = m/a$ as the secant of zero is the unity.

LOAD TERMINATED BY A CIRCULAR OR ELLIPTICAL ARC: He gives the equation of the curve of equilibrium for a load defined by a horizontal extrados terminated by a circular or elliptical intrados. (211) This is the case of a masonry bridge when the filling has the same specific weight as the arch-stones, which will be in a real bridge only a very crude approximation. "When the load is terminated by a circular or elliptical arc, $w = a + nb - n \sqrt{b^2 - x^2}$ and

$$\begin{aligned}
 my = & \frac{1}{2} (a + nb) x^2 - \frac{1}{2} nb^2 x \arcsin \left(\frac{x}{b} \right) - \\
 & - \frac{1}{2} nb^2 \sqrt{b^2 - x^2} + \frac{1}{6} n (b^2 - x^2)^{\frac{3}{2}} + \frac{1}{3} nb^3 x.
 \end{aligned}
 \tag{8}$$

The expression of the load may be immediately deduced for a circular form and the coefficient n represents only an stretching to obtain an ellipse (for the circular form $n = 1$). Young makes correctly the corresponding integrals, obtaining the above cited mathematical expression. The radius of curvature at the vertex will be again $r = m/a$. Young will apply later this expression in the calculation of the curve of equilibrium of Blackfriars Bridge.

DISCUSSION ON CURVES OF EQUILIBRIUM WITHOUT FRICTION: Young states that the condition for the equilibrium of an arch without friction is that “a curve of equilibrium, perpendicular to all the surfaces of the joints, must be capable of being drawn within the substance of the blocks”. (212) This is, of course, the essence of the equilibration theory and Young dedicates two pages to criticize this, preparing the reader for his last proposition on the effects of friction. In fact, in this paragraph, he will discuss the formation of hinges, the corresponding diminution of “strength” (the increase of the stresses) and the way of collapse of masonry bridges.

He asserts that, in practice, the possibility of failure by sliding is almost impossible, but “if the curve [of equilibrium] . . . be directed to a point in its plane beyond the limits of the substance, the joint will open at its remoter end, unless it be secured by the cohesion of the cements, and the structure will either wholly fall, or continue to stand in a new form.” (212) It appears that for the first time there is established a relationship between line of thrusts and the formation of hinges, and the possibility of an arch to adapt to the movements by cracking. Young does not expand the statement but refers the reader to the *fig. 5* in figure 4. (In the *Miscellaneous papers* Peacock eliminated all the comments on the plates.) He says that, in this situation, “the joints in the neighbourhood of D [and E] will be incapable of resisting the pressure in the direction of the curve CD, and must tend to turn on their internal terminations as centres, and to open externally” (Young 1824, 520).

Then Young comments the reduction of strength when the curve of equilibrium touches the limit of the arch; in this situation the stress is four times higher as the mean stress, equation (2). But Young is well aware that this is in the hypothesis of plane deformation and the existence of cohesion (tensile strength) and that in

reality "the diminution of strength will probably be considerably greater than is here supposed, whenever the curve approaches to the intrados of the arch". (213)

Finally, he discussed the problem of the process of collapse of a real bridge, *fig. 6* in figure 4. He is not considering a rigid material and, therefore, the deformations are not concentrated exclusively at the hinges (though the cracks at the haunches are clearly drawn). In fact, he is trying to explain the results of some experiments reported by Robison (1801) with the help of his new ideas on curves of equilibrium.

EFFECT OF FRICTION: In this part Young resumes the main consequences of friction in respect to the stability of arches and of masonry structures in general: "The friction or adhesion of the substances, employed in Architecture, is of the most material consequence for insuring the stability of the works constructed with them". (214) With respect to arches, he realized crucial importance of friction to let the curve of equilibrium move, within the arch. The corresponding (and last, of the theory of arches) proposition resumes the main aspects: "The joints of an arch, composed of materials subject to friction, may be situated in any direction lying within the limits of the angle of repose [friction] . . ." (215)

He concludes "that the direction of the joints can never determine the direction of the curve of equilibrium crossing them, since the friction will always enable them to transmit the thrust in a direction varying very considerably from the perpendicular", (216) though he adverts also, that sometimes the true direction of the joints should be taken into account, as they affect the form of the curve of equilibrium and the direction of the thrusts and in this case: ". . . with respect to any particular joint, of which we wish to ascertain the stability independent of the friction, it would be desirable to collect the result of the elements, of which that curve is the representative, with a proper regard to its direction."

Analysis of Telford's design for London Bridge

The objective of Young in writing the article *Bridge* was not to give another mathematical discussion on the theory of arches, similar to that of Hutton or Atwood. He wants to develop a theory to be applicable to the design of real bridges. Therefore, after the theoretical parts on *Strength of Materials* and *Theory of Arches*, he passed on to apply his theory to real cases. He first addresses his attention to Telford's design. His appreciation of the answers given by the experts to the questions posed by the Select Committee, which he no doubt read with great care, is unambiguous: ". . . the results of these inquiries are not a little humiliating to the admirers of abstract reasoning and of geometrical evidence; and

it would be difficult to find a greater discordance in the most heterodox professions of faith, or in the most capricious variations of taste, than is exhibited in the responses of our most celebrated professors, on almost every point submitted to their consideration". (225) Young must have considered a challenge to be able to succeed where the most eminent professors, engineers and practitioners have failed. However, his objective was not to exercise a bitter criticism; he saw in the questions many fundamental aspects of bridge design and used them as line of argument to direct the reader to the whole process of bridge design: "It would be useless to dwell on the numerous errors with which many of the answers abound; but the questions will afford us a very convenient clue for directing our attention to such subjects of deliberation as are really likely to occur in a multiplicity of cases; and it will perhaps be possible to find such answers for all of them, as will tend to remove the greater number of the difficulties which have hitherto embarrassed the subject."

In what follows we will examine only those answers directly relevant to arch design and analysis. The complete, numbered, list of questions is given in the Appendix at the end of this paper.

What is structure? Arch or frame behaviour (Question I)

The design presented by Telford is very complex and Question I addresses the first crucial stage in the structural analysis of any building construction: What parts of the work form the structure? In particular, the question makes an explicit division in two ways of structural behaviour: the "arch" (working in compression) and the "frame" (with members either working in compression or in tension).

The answer of Young is extremely lucid. He argues first that the analyst has some freedom in the way to consider the behaviour of the structure, but also that the load tend to follow the paths formed by the more rigid parts of the structure: "there is also a natural principle of adjustment, by which the resistance has a tendency to be thrown where it can best be supported". (225) Then follows a discussion on the functioning of the several arch ribs which can be seen in the design. He concludes that the transmission of the load concentrates in the lower ribs: the upper, flatter, ribs which produce a greater thrust and an slight movement of the buttress will relieve the load from them and transmit it to the lower ribs. It is, then, the lower ribs which transmit the load and it is the lateral thrust produced by them which governs the design, and not the strength of the material which constitutes the arch. Also, the thrust will be less if the load is concentrated in the inferior ribs, and all the circumstances contribute to that "natural adjustment" cited above.

The arch transmits most of the load. The frame may contribute "affording a partial resistance if required . . . the principal part of the force ought to be concentrated in the lower ribs, not far remote from the intrados". But he remarks

again that the line of thrust, the curve of equilibrium, must not coincide with the intrados (in fact this will produce an overstressing of the arch), nor have to be parallel to it, as it has considered until then.

Finally he relates the nature of the material with the structural type: arches work mainly in compression, and the utility of cast iron lies in his good compressive strength and not in the possibility of connecting different members forming a truss: "the true reason of the utility of cast iron for building bridges, consists not, as has often been supposed, in its capability of being united so as to act like a frame of carpentry, but in the great resistance which it seems to afford to any force tending to crush it".

Curve of equilibrium for dead load (Question III)

Question III is formulated within the frame of the equilibration theory, in which there is a direct relationship between the load and the form of the arch. To discuss the matter in depth, Young says; "would involve the whole theory of bridges" (228) and that he will limit the discussion to the proposed structure, in order to ascertain its strength and, if necessary, to suggest "any alterations . . . compatible with the general outlines of the proposal, to remedy any imperfections which may be discoverable, in the arrangement of the pressure". He is going, then, to make an analysis of the arch ribs, as forming the structure which supports the whole weight of the bridge.

He begins stating that the equilibration theory does not afford a means to analyze the bridge as the distribution of the loads "differ so materially from that which is required for producing an equilibrium in a circular arch of equable curvature" and this has led some experts to consider the whole structure a frame or truss (cf. Fig. 8, above).

Young insists again in what was his main contribution to arch theory, to free the curve of equilibrium from the form of the arch and he states this with utmost clarity: "The truth is, that it is by no means absolutely necessary, nor often perfectly practicable, that the mean curve of equilibrium should agree precisely in its form with the curves limiting the external surfaces of the parts bearing the pressure, especially when they are sufficiently extensive to admit of considerable latitude within the limits of their substance". (229) The arch requires a certain thickness to contain with ease a curve of equilibrium, as its form does not coincide with that of the arch; implicitly Young is here considering a geometrical factor of safety. The problem of the analysis is, then, "to determine the precise situation of the curve of equilibrium in the actual state of the bridge". After this a check should be made relating the safety of the joints "and if this security is not deemed sufficient, the whole arrangement must be altered".

Now Young passes to apply the general Propositions on the equilibrium of arches to analyze Telford's design. He considered all the load concentrated in a "typical" plane arch rib of the dimensions stated in Telford's design and supposes that this load has a parabolic form $w = a + bx^2$. From an inspection of the general form of the bridge (and, also probably from the estimations of the weights given by some experts in the Fourth Report though he is not explicit about it) he considers that the load is about three times greater in the abutments as in the crown. Then, for $x = 300$ feet, $w = 3a$ and $90,000b = 2a$, so that $b = (1/45,000)a$. Substituting this values in equation (8) he obtains the equation of the curve of equilibrium

$$my = \frac{1}{2} ax^2 + \frac{1}{540000} ax^4 \quad (9)$$

there are two constants m (the horizontal thrust) and a the height of the load at the keystone.

Young considers that the curve of equilibrium should pass through the middle of the keystone and, also, through the middle of the vertical section at the springings. The circular arch of intrados is defined by the span (600 feet) and height (65 feet), and this leads to a radius of 725 feet, with a total angle of aperture of $2 \times 24.45^\circ = 48.9^\circ$. The arch of extrados can be deduced from the drawings in the Fourth Report (Fig. 2, above): taking the middle of the extreme ribs, the thickness at the keystone is 8 feet and at the springings 10. The vertical section at the springings will be a little greater (by a factor $(1.08 = 1/\cos(22.45^\circ))$), but disregarding this, vertical distance between the middle points of both vertical sections will be 64 feet. Of course, Young does not explain all this and only says: "Now the obliquity to the horizon being inconsiderable, this ordinate will not ultimately

Distance x .	Versed sine of the intrados.	Versed sine of the circular arc.	Ordinate y .
50	1.73	1.71	1.34
100	6.94	6.82	5.38
150	15.66	15.43	13.00
200	28.13	27.70	24.50
250	44.42	43.81	41.01
300	65.00	64.00	64.00

Table 1

Ordinates of the intrados, the middle line of the arch and of the curve of equilibrium, calculated by Young for Telford's design for London Bridge (1817).

be much less than the whole height of the arch; and its greatest value may be called 64 feet”.

At the springings $x = 300$ and $y = 64$, and substituting in equation (9) we obtain $m/a = 937.5$ feet, which is precisely the radius of curvature of the curve of equilibrium at the crown. (We may compare this value with the radius of the intrados of 725 feet.) Substituting this value again in equation (9) we obtain the expression of the curve of equilibrium:

$$y = \frac{1}{1875} x^2 \left(1 + \frac{1}{270000} x^2 \right) \quad (10)$$

Now, Young calculates the ordinates at different points and makes a table to compare the ordinates of the curve of equilibrium with those of the line of intrados and with the middle line (the circle passing through the middle of the keystone and the vertical section at the springings), Table 1.

Young finds a maximum vertical distance of 3.20 feet (the radial distance being nearly 3 feet) between the middle line and the curve of equilibrium at 200 feet from the center, that is, only a little more than one foot apart from the border and this will produce a great compression on this section: “. . . the curve of equilibrium will rise more than 3 feet above its proper place; requiring a great proportion of the pressure to be transferred to the upper ribs, with a considerable loss of strength, for want of a communication approaching more nearly to the direction of the curve”. (230) (In fact, if we displace the curve of equilibrium 1.6 feet downwards, this will be the maximum distance from the middle line, which will be almost contained within the middle third of the section, as the vertical thickness will be at this point 8.9 feet. This device is used later in the analysis of Blackfriars bridge.)

Young finds the discordance between the form of the curve of equilibrium and that of the arch excessive and says “it would, however, be much better to have the arch somewhat elliptical in its form, if the load were of necessity such as has been supposed”.

Internal forces in the arch, and thrust against the abutments (Question IV)

The question is, again, formulated within the frame of the equilibration theory. If the curve of equilibrium has the form of the intrados then, knowing the load at the keystone the thrust may be calculated directly, but Young remarks that: “It appears from the preceding calculations. that the weight of the ‘middle section’ alone is not sufficient for determining the pressure in any part of the fabric . . .”. (231) But if we know the expression of the curve of equilibrium we may calcu-

late directly its radius of curvature r and the horizontal thrust is (eqn 9) $m = ra$, being a the depth of the load at the crown; "and by combining this thrust with the weight, or with the direction of the curve, the oblique thrust at any part of the arch may be readily found". (231)

Now Young gives a simple procedure to do this. For the case studied (parabolic load), the form of the curve is defined by the form of the load (the relation between a and b) and the points of passage of the curve. The value of a remains undefined. Young, now, set himself to obtain this value. To do this he established the general equilibrium of the half arch: at the springings the thrust must give a vertical component equal to the weight of the half arch, i. e., the tangent of the curve of equilibrium must be equal to W/m , being W the weight of the half arch and m the horizontal thrust. At the abutments $w = a + bx^2 = 3a$, so that $bx^2 = 2a$.

Differentiating the general equation of the curve of equilibrium (eqn. 9, above) we obtain $\frac{dy}{dx} = \frac{a}{m}x + \frac{1}{3} \frac{b}{m}x^3$, and at the abutments, $bx^2 = 2a$, $\frac{dy}{dx} = \frac{5}{3} \frac{a}{m}x = \frac{5}{3} \frac{x}{r}$. For $x = 300$ feet and $r = 937.5$ feet; $dy/dx = 0.5333 = 8/15$, nearly. Therefore, the horizontal thrust at the abutments will be $15/16$ of the total weight of the bridge. Now, this weight was estimated by Robison in 10,000 tons (6,500 tons of cast iron, plus the weight of the road), and the horizontal thrust will be $m = 9470$ tons. The load at the keystone will be, then, $a = m/r = 9470/937.5$ or nearly 10 tons. (The surface of the road over the bridge being nearly 18,000 square feet and the total weight of the road 3,500 tons, the superficial load will be 0.20 tons/feet², which at the keystone, will lead to a total load $0.20 \times 45 = 9$ tons, the difference being the weight of the ironwork on this place, which is plausible.)

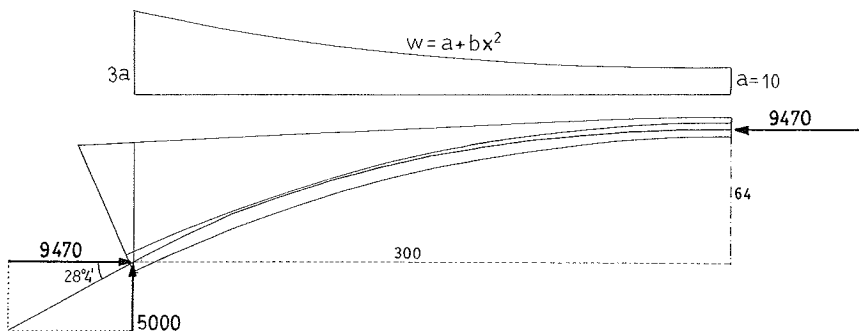

Figure 9

Equilibrium of the arch ring of Telford's design for a dead load of parabolic form. The curve of equilibrium passes through the middle of the joints at the crown and abutments.

Young notices that, though the thrust is greater than the calculated by the equilibration theory applied at the crown (the radius of curvature of the curve of equilibrium is greater than that of the intrados), it is less than will be expected from the inclination of the intrados at the springings, $24^{\circ}27'$ in comparison with the inclination of the curve of equilibrium, $\text{atn}(8/15)$ or $28^{\circ}4'$. Another proof of the inconsistency of the old theory.

BLACKFRIARS BRIDGE: Now Young, comes back again to the matter of calculating the curve of equilibrium and takes as an example Blackfriars Bridge, which was considered then one of the best examples of stone bridge. The curve of intrados has three centres (Fig. 10) and the radius of curvature of the central part ($4/5$ of the span) is 56 feet. Young considers that the continuation of this arch will give very nearly the distribution of the load (the shaded curved triangle ABC in figure 10 is the difference).

Then we are in the case of a load determined by a horizontal extrados and a circular intrados (eqn. 8, above). Now Young determines that the curve should pass through the middle of the keystone, 3 feet above the intrados, and the middle of the vertical section at the springings, which he estimates in 12 feet. If the height of the arch is 40 feet, the height of the curve of equilibrium will be $40 + 3 - 12 = 31$ feet. The total thickness at the crown is 6.58 feet (6 feet of the keystone plus 0.58 of the road). Therefore the load will be proportional to this quantity and Young takes $a = 6.58$. Substituting in equation (9), we obtain $my = m \cdot 31 = 13.510$, and then $m = 436$ feet, a quantity proportional to the horizontal thrust. The radius of curvature at the keystone is $r = m/a = 66.25$, i.e., as in Telford's design greater than the radius of the intrados.

Now he calculates the ordinates of the curve of equilibrium, for different values of x and also calculates the ordinates of the middle line of the arch, a circular arc of cord 100 feet and height 31 feet (radius of 55.8 feet, almost the same as

Distance x .	Ordinate y .	Middle of the Arch-stones.
10 feet	.76	.90
20	3.12	3.72
25	5.13	6.12
30	7.71	8.75
40	15.81	16.81
50	31.00	31.00

Table 2

Ordinates of the curve of equilibrium and the middle line of the arch in Blackfriars Bridge. (Young 1817)

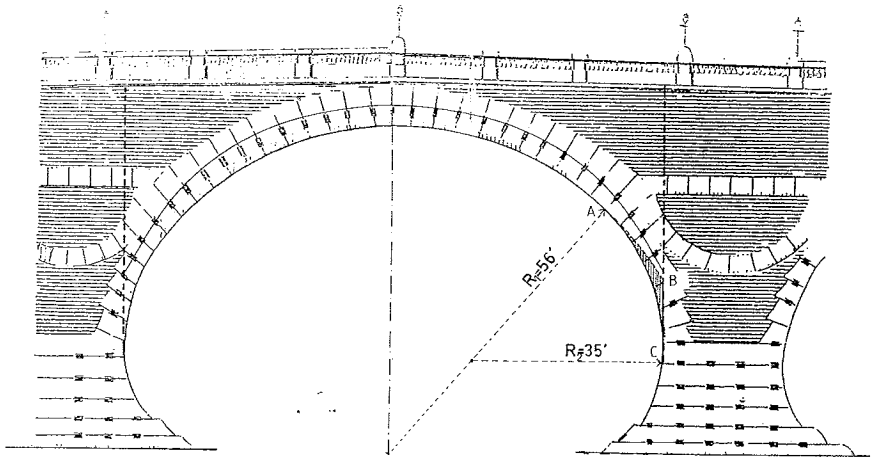

Figure 10

Section of Blackfriars bridge with the curve of equilibrium calculated by Young drawn on it by the author.

that of the intrados). He forms a Table to check the deviation of the curve of equilibrium from the middle line, Table 2: "Hence it appears that the greatest deviation is about 30 feet from the middle, where it amounts to a little more than a foot." (232) At this point, the radial deviation will be nearly $1.04 \times 0.84 = 0.88$, to be compared with a thickness of a little more than 6 feet.

Now Young makes one crucial comment. Until now the curve of equilibrium have had to pass through the middle of the sections at the springings and the keystone. He proposes now to displace downwards the curve of equilibrium half of the vertical distance, so that it will deviate the same quantity at the three critical points: "But if we suppose this deviation divided by a partial displacement of the curve at its extremities . . . it would be only about half as great in all three places; and even this deviation will reduce the strength of the stones to two-thirds, leaving them however still many times stonger than can ever be necessary." Indeed, for a deviation of 0.5 feet and a thickness of 6 feet, the mean stress will be multiplied by a factor $(6 + 6(0.5))/6 = 3/2$ (eqn. (2), above), which Young interprets as a reduction of $2/3$ of the total strength of the section.

The calculated value of m represents a quantity proportional to the real thrust: ". . . the horizontal thrust is here compressed by $m = 436$, implying the weight of so many square feet of the longitudinal section of the bridge; while, if we determined it from the curvature of the intrados, it would appear to be

only $56a = 368''$. (The calculated thrust being almost 20% greater than the value of the old equilibration theory.) If we call γ the specific weight of the masonry and l the breadth of the bridge, the total thrust will be $436(\gamma l)$.

Young tries in this example to be very minute with every detail and passes to discuss the influence of the direction of the joints and the consideration of the different specific gravities of the materials, but concludes that "so minute a calculation is not necessary in order to show the general distribution of the forces concerned, and the sufficiency of the arrangement for answering all the purposes intended". (233)

Effect of an additional weight placed anywhere over the bridge (Question V)

This is the most difficult question to answer as it implies the analysis of an asymmetrical load. Arch theory has been confined to symmetrical arches and loads until the second half of the XIXth century. This constitutes, again, a challenge to Young as there were no precedents of such an analysis. Young recognizes that a weight placed on the arch will modify the form of the curve of equilibrium: "When a weight is placed on any part of a bridge, the curve of equilibrium must change its situation more or less, according to the magnitude of the weight". Now he affirms, maybe thinking in the analogy with an inverted frame polygon that: "the tangent of its inclination must now be increased by a quantity proportional to the additional pressure to be supported, which, if the weight were placed in the middle of the arch, would always be equal to half of it". To estimate this change of inclination the best way is to find the point where the new curve of equilibrium (dead load plus the additional weight) is horizontal because in this case "the vertical pressure to be supported at each point of the curve must obviously be equal to the weight of the materials interposed between it and this new summit of the curve". (233)

This last observation permits him to locate this point of horizontal thrust. With reference to figure 11, where we have a bridge with a total weight W which supports an additional load Q located at a distance b from the nearest abutment. Obviously, the vertical reactions will be that shown in the figure and the weight P of the load between the point of horizontal tangent and the keystone is $(b/s)Q$, and therefore:

$$\frac{P}{Q} = \frac{b}{s} \quad (11)$$

Young express this relation as follows: "the distance of the new summit of the curve from the middle must be such, that the weight of materials intercepted be-

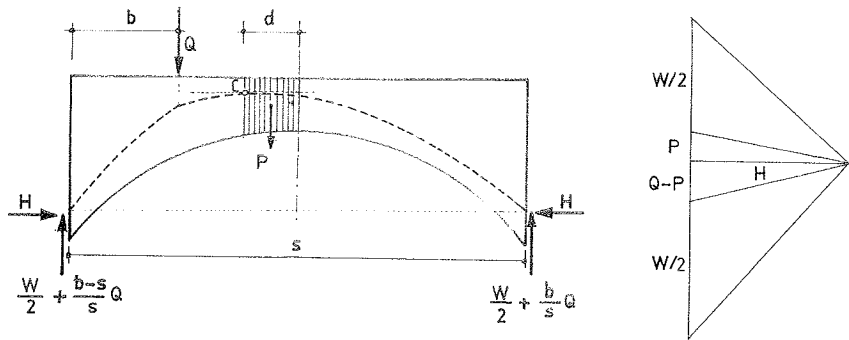

Figure 11

Calculation of the point of horizontal tangent in the curve of equilibrium distorted by the action of an additional weight.

tween it and the middle shall be to the weight as the distance of the weight from the end to the whole span" (234) and gives no demonstration.

Once this point is found "the tangent of the inclination must everywhere be increased or diminished by the tangent of the angle at which the lateral thrust would support the weight of this portion of the materials; except immediately under the weight, where the two portions of the curve will meet in a finite angle, at least if we suppose the weight to be collected in a single point".

Young explains the procedure applying it to Telford's design: "If, for example, a weight of 100 tons, equal to that of about 10 feet of the crown of the arch, be placed half-way between the abutment and the middle; then the vertex of the curve, where the thrust is horizontal, will be removed $2\frac{1}{2}$ feet towards the weight." Applying the above formula $(P/100) = (600/150) = 1/4$, then, $P = 100$ tons, which considering the load uniform this distance, which is very nearly true, is equivalent to the weight of 2,5 feet of the load at the crown (which was calculated before as 10 tons), and the horizontal thrust have been calculated as 937.5 feet of the same load. The objective is to deduce the new curve of equilibrium, dead plus additional weight, transforming the curve of equilibrium for the dead load. He explains the procedure in a synthetic way:

. . . so the tangent of the additional inclination will be $2.5/937.5 = 1/375$, and each ordinate of the curve will be increased $1/375$ of the absciss, reckoning from the place of the weight to the remoter abutment; but between the weight and the nearest abutment, the additional pressure at each point will be $10 - 2.5 = 7.5$ feet, consequently the tangent will be $1/125$, and the additions to the ordinates at the abutments will be $450/375$

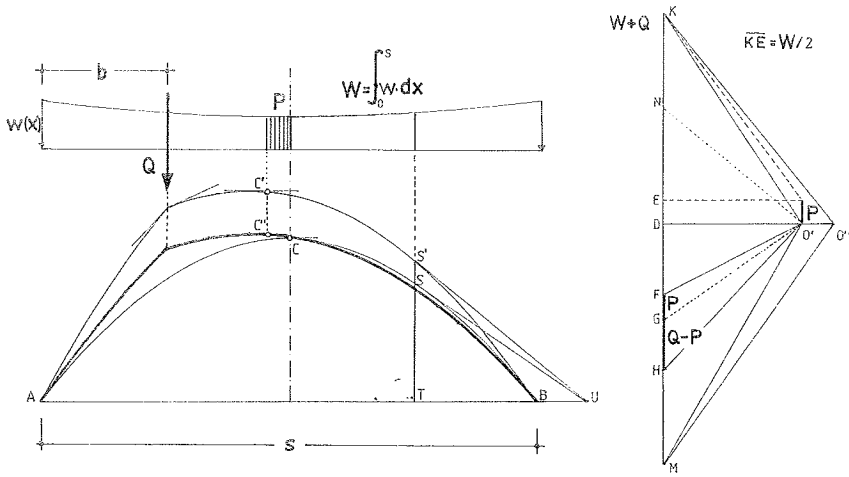

Figure 12
Graphical explanation of Young's method of obtaining the curve of equilibrium for dead plus additional weight, transforming the curve of equilibrium for dead load.

and $150/125$, each equal to $1 (1/5)$ foot, and at the the summit $150/375 = 2/5$, which, being deducted, the true addition to the height of the curve will appear to be $4/5$. But the actual height will remain unaltered, since the curve is still supposed to be terminated by the [middle of the] abutments, and to pass through the middle of the key-stone; and we have only to reduce all the ordinates in the proportion of 64.8 to 64 .

The procedure is completely correct and shows a enormous ingenuity and is based in the properties of the tangents of the sides of a funicular polygon. figure 12 tries to explain the procedure graphically, with the aid of the force polygon.

Following the method it is very easy to calculate the ordinates of the new curve of equilibrium and to study its deviation from the middle line. In Table 3 we have tabulated the results:

The additional weight is located at $x = -150$ feet from the crown. Young only studies what he considers the critical points: the nearest point of the curve of equilibrium of the dead load, at $x = 200$ feet, and the point directly under the load. In the first case, "... at 200 feet from the summit the ordinate, instead of $24.50 + 200/375 = 25.03$, will be 24.72 , so that the curve will be brought 2fi inches nearer to the intrados, which, in the proposed fabric, would by no means

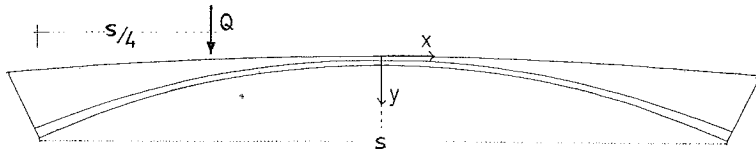

x	y_m	y	y_q	$y_m - y$	$y_m - y_q$
-300	64	64	64	0	0
-250	43.82	41.04	40.93	2.77	2.88
-200	27.73	24.49	24.18	3.24	3.54
-150	15.46	13.00	12.43	2.46	3.03
-100	6.83	5.53	5.19	1.30	1.63
-50	1.70	1.34	1.19	0.35	0.50
0	0	0	0	0	0
50	1.70	1.34	1.45	0.35	0.24
100	6.83	5.53	5.72	1.30	1.10
150	15.46	13.00	13.22	2.46	2.24
200	27.73	24.49	24.71	3.24	3.01
250	43.82	41.04	41.19	2.77	2.62
300	64	64	64	0	0

Table 3

Ordinates of different curves and their vertical distances from the middle line of the arch. Origin at the middle point of the keystone: y_m , middle line of the arch; y , curve of equilibrium for dead load; y_q , curve of equilibrium dead plus point load.

diminish its strength" (the slight differences in the table are due to the rounding of the calculations). In the second case, the disturbance is greater: "... immediately under the weight, the ordinate $13 - 150/375 = 12.6$ will be reduced to 12.45, and the curve raised between six and seven inches, which is a change by no means to be neglected in considering the resistances required from each part of the structure". (235) In fact, as may be seen in the Table 3, though the movement of the second point is much greater, the distance of the curve of equilibrium to the limit of the arch is almost the same. The greatest deviation is found 50 feet nearer the abutment ($x = -200$) and is 3.54, equivalent to a radial deviation of 3.7 feet, in a place where the radial thickness is nearly 9 feet.

Now, looking at Table 3 is evident that most of the curve of equilibrium is over the middle line (only some 20 feet apart from the crown on the right side is under it), so, to reduce the stresses Young may have been used the same procedure applied in the analysis of Blackfriars bridge, to displace the line downwards half the greatest distance, i. e. $3.54/2 = 1.77$. This will be the greatest deviation and the curve of equilibrium will be comfortably within the middle half of the section and only a little outside of the middle-third.

Finally, he stresses that the total thrust increases very little in comparison with the thrust of the dead load only. The problem of the action of an additional weight is the distortion produced in the curve of equilibrium, not the increase on the thrust.

Best form of the arch and dimensioning of its members (Question VII)

The question refers to the influence of the degree of surbaissement on the thrust and internal stresses and also to the possible advantages of an elliptic profile. Young answers to both questions but includes, also, a discussion on the strength of materials and the possible sections of the main ribs.

To discuss the effect of an increase of the height of the arch some assumption as to the variation of the load must be made; Young supposes that the weight remains constant and it is evident that he is thinking in a vertical "stretching" of the original form. In this case the vertical position of the center of gravity does not change and the thrust will diminish in the same ratio as the height grows. A change from 65 to 75 feet height will suppose to pass in the studied curve of equilibrium from 64 to 73 and the thrust will be reduced from 9470 tons to 8300 tons. Being an affine transformation the value of the thrust diminishes, but the relative deviation from the middle line will remain the same: "The additional thrust occasioned by any foreign weight would also be lessened, but not the vertical displacement of the curve derived from its pressure; and since the whole fabric might safely be made somewhat lighter, the lightness would again diminish the strain". (236) This assertion is another proof of the deep grasp of Young on the geometrical properties of the lines of thrust.⁵

Then Young discusses in some detail the problem of the strength of the materials and its role in the design of the main ribs of the arch. He considers that a moderate value of the crushing strength of cast iron is about 50 ton./sq.in. [800 N/mm^2]. The total oblique thrust is 10,730 tons which divided by 50 gives an area of 215 inches and which he multiplies by three to obtain a section of 600 sq.in., which will suppose nearly as many tons of cast iron in the ribs "upon this very low estimate of the strength of cast iron." (237)

In fact, to make cast iron work at one 1/3 of its strength $50/3 = 16.7$ ton/square inc, or 270 N/mm^2 , is by no means a "very low estimate". Even for constructive

reasons would have been impossible to divide this area between the thirteen ribs of the design.

Skempton (1980) estimates from the drawings a section of 100 sq. inches per rib, and that will mean 1300 sq. in., and the stress will be less than one half, $10730/1300 = 8.25$ tons/sq.in [130 N/mm²]. However, Skempton notices the reduction of the strength for slender pieces, and comparing with stresses in contemporary buildings and bridges, considers an stress around 4.5 tons/sq.in. as exceptionally high (and that means a coefficient of 1/10 of the crushing strength!). But Young is mainly concerned with supplying the internal forces in the arch. (No doubt, would Telford's design have been accepted, in situ tests of specimens would have been made as was usual with any great iron construction.)

Now Young treats the case of stone bridges and discuss their limit spans: "Calcareous freestone supports about a ton on a square inch [15 N/mm²], which is equal to the weight of a column not quite 2000 feet [600 m] in height". Young is using here the parameter invented by Perronet and used by Gauthey (Huerta 2004) to measure the crushing strength of a material: the height of a column of uniform section which just collapses at the base $h_l = \sigma_c / \gamma$, where σ_c is the crushing strength and γ the specific weight of the material. (The value of 2000 feet seems very moderate and Rankine (1858) gives this figure for weak sandstone; ordinary sandstone having a double strength and granite five times more, with limit heights of 4000 and 10000 feet, or 1.2 and 3 km respectively.)

Then, he discusses the maximum span which can be attained by stone arches: ". . . consequently an arch of such freestone, of 2000 feet radius, would be crushed by its own weight only, without any further load". In an arch of catenarian form, which supports its own weight the stress at the keystone is $\sigma = r\gamma$, where r is the radius of curvature and the limit radius $r = h_l = \sigma_c / \gamma$. Therefore, ". . . for an arch like that of a bridge, which has other materials to support, 200 feet is the utmost radius that it has been thought prudent to attempt; although a part of the bridge of Neuilly stands, cracked as it is, with a curvature of 250 feet radius; and there is no doubt that a firm structure, well arranged in the beginning, might safely be made much flatter than this, if there were any necessity for it". Young is exhibiting a great confidence in iron and distrust for masonry, an attitude which will grow during the whole XIXth century, but which has no scientific basis.⁶

As for the form of the arch, Young insists in the advantages of the elliptical form, as it adapts itself better to the form of the curve of equilibrium.

Use of scale models (Questions VIII and IX)

It is considered the kind of model to be used in ascertaining the safety of the design and of what size should be built. Young is very clear about the matter: hanging models will permit to check the stability of the arch, but if the model tries to

study the effect of "the cohesion or connection of the parts" the results will be "extremely uncertain".

Young explicits the mode in which the experiment should be made: "the parts corresponding to the blocks of the arch should be formed of their proper thickness and length, and connected with each other and with the abutments by a short joint or hinge in the middle of each, allowing room for a slight degree of angular motion only . . . [and] if the curve underwent no material alteration by the suspension, we should be sure that the calculation was sufficiently correct". If this is not the case, "the arrangement of the materials might be altered". He, then, makes a suggestion to ease the use of the model: ". . . the investigation might be facilitated by allowing the joints or hinges connecting the block to slide a little along their surfaces, within such limits as would be allowable, without too great a reduction of the powers of resistance of the blocks".

There is no drawing, but the text may be interpreted as hanging block model. The size of the blocks calculated in function of their respective weights and the hinges located within the section of the arch and allowing a vertical displacement within it. This interpretation has been represented in figure 13.

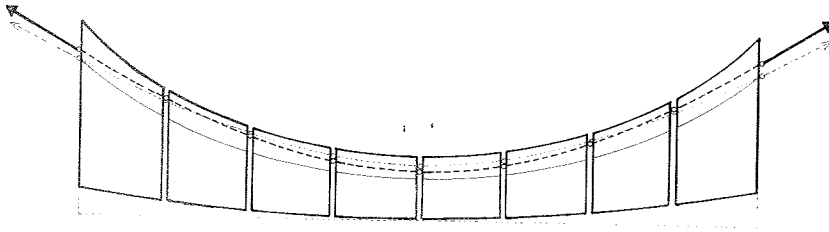

Figure 13

Hypothetical reconstruction of Young's hanging-block model. The hinges can move vertically within the ring of the arch, materializing different curves of equilibrium.

As for the size of the model, he states that it "is of little importance, and it would be unsafe to calculate the strength of the bridge from any general comparison with that of the model".

Design and construction of the abutments (Question XI)

This is a most important question. Flat arches produce a great thrust and, besides, the thrust has a considerable inclination, so that the danger of failure by sliding must be considered. Young, apparently considers the preliminary design of Telford as insufficient and makes a number of suggestions.

Of course, the matter is heavily dependant on the nature of the soil. Young cites the case of St. Saviour's church, built nearby, as a proof of a soil of moderate quality. Besides he considers that, if the foundation rests on piles the sufficient degree of safety may be acquired.

Then proceeds to suggest the general disposition and dimensions of secure abutments in the case of a soft soil, employing piles so that the total weight mobilized to resist the thrust reach 100,000 tons, the main objective being to prevent absolutely a failure by sliding: "When, indeed, the earth is extremely soft, it would be advisable to unite it into one mass for a large extent, perhaps as far as 100 yards in every direction, for such a bridge as that under discussion, by beams radiating from the abutments, resting on short piles, with cross pieces interspersed; since we might combine, in this manner, the effect of a weight of 100,000 tons, which could scarcely ever produce a lateral adhesion of less than 20,000, even if the materials were semifluid" (242)

Then, comments the proper direction of the joints of masonry within the buttress, a matter of enormous importance in the case of surbaissée arches: the masonry should be built with the joints normal to the direction of the line of thrust within the buttress. Finally, he recommends that the piles at the base of the buttress should be driven following the direction of the thrust at the extreme of the curve of equilibrium.

The design of the abutments proposed by Telford has been minutely examined by Skempton (1980). He estimates the weight of the abutments in 63000 tons and calculates that the thrust at the base is well inside the middle third and produces a maximum pressure of 5 tons/sq.ft. [550 kN/m²]. But, Skempton makes a particular study of the differential settlement at the base of the abutments and gives a table of its evolution. He estimates the final tilt, after the complete consolidation of the soil, in 0.3°, leading to a total spreading of 4 inches. Skempton sees in this a serious inconvenient and cites the case of Staines Bridge "which suffered severe damage and had to be taken down, as the result of a 3 in. movement of one of the abutments. Its span was 181 feet. Once again, then, we find a very uncomfortable feature in the design; especially when it is remembered that the rib stresses would have been exceptionally high even without the yielding of the abutments". (Skempton 1980)

No doubt Skempton calculations of the inclination of the buttresses are correct, but it is difficult to believe that such a tiny movement of the abutments, would have had such an enormous effect as it is supposed to have caused in Staines Bridge. There the displacement was $\frac{3}{181 \times 12} = 1/724$ of the span, which looks very moderate; but in London Bridge, it amounts to 1/1800 of the span. The yielding of the buttresses would have produced the typical three-hinge pattern, with a concentration of stress, but it appears that cast iron has sufficient

compressive strength to withstand this effect, in the same way as stone arches have made during centuries or millennia (for the calculation of cast iron arches, see Heyman 1982). Young's modifications would have reduced notably the value calculated by Skempton.

Possible improvements and safety of the design (Questions XIX and XX)

The rest of the questions address mainly practical matters: the construction of the scaffolding, the type of iron to be used, the possibility of casting the members with sufficient precision, the size of the castings, the use of "iron cement", etc. However, questions XIX and XX imply a summary of the main arguments and will be examined.

Young suggest to eliminate the upper flatter ribs and reinforce the lower ribs forming the arch and, also, "made either in the form of blocks or of frames with diagonals" (245) (following presumably the model employed by Telford in his iron bridges after Bonar Bridge). The profile of the ribs should adjust better to the form of the curve of equilibrium.

Then he treats in some detail the problem of decentering, closely related with the apparition of cracks and concentrations of stress: "It would be necessary to wedge the whole structure very firmly together before the removal of the centres", following a method similar as that employed for stone bridges and which is intended "to enable the stones to bear fully on each other, and which has been very properly adopted in the best modern works". (All this precautions, leading to a certain pre-compression of the voussoirs, may lead to a diminution of the descent of the crown. Another traditional device, which was applied to flat arches and vaults, was to built the arch or vault with an initial stilt so that after deformation will take the desired profile.)

As for the feasibility of the design, Young expresses no doubt about it, and, in fact, he has given the theory and practical calculation tools developments to make all the necessary analysis and corrections of the original design. He insists, again, that the main problem is in the design of the abutments: "The only reasonable doubt relates to the abutments; and with the precautions which have been already mentioned in the answer to the 11th question, there would be no insuperable difficulty in making the abutments sufficiently firm."

Analysis of other "modern" bridges: Southwark and Waterloo Bridges

As has been mentioned in the version of the article "Bridge" printed in the *Miscellaneous papers*, the last section of the original article, with the title "Modern History of Bridges", was completely suppressed. In fact, only the first part of the section is a brief history of the first iron bridges constructed. The second part

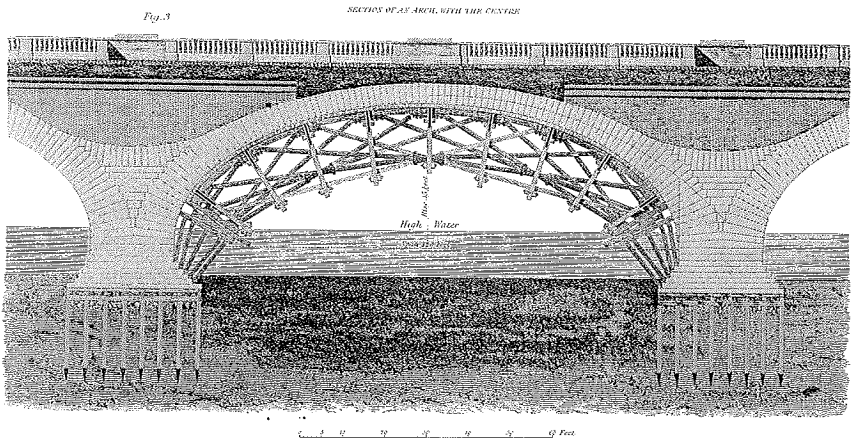

Figure 14

Waterloo Bridge. The curve of equilibrium as been drawn on the right hand half arch. It is the first time that a line of thrust is drawn to explain the stability of a real bridge. (Young 1817)

contains the application of Young's theory of the arch to the analysis of two important bridges: Southwark and Waterloo bridges. This suppression is a grave affair as some parts of the article are difficult, if not impossible, to understand without looking at the calculations made above the cited bridges. Also, the section confirms the main objective of Young: to provide a theory of arches directly applicable to the analysis and design of actual bridges. There is no space here to discuss the ingenuity with which he applied his own theory to the analysis of real bridges. But maybe a good manner to finish this paper is with, perhaps, the first drawing of a line of thrust within an arch bridge, in figure 14.

Conclusions

1. Thomas Young has a deep understanding of the concept of "line of thrust", which he called curve of equilibrium. He formulated and employed this concept nearly twenty years before other authors.
2. He was the first to free this curve from the "straitjacket" of the intrados, the curve depending on the load distribution and expressing the infinite possible equilibrium situations in which an arch may transmit its loads.
3. For arches of stone or cast iron, materials with good compressive strength but low tensile strength the curve of equilibrium must lie within the sub-

- stance of the arch, with some geometrical safety, i.e. the curve should not approach too much to the borders.
4. Young obtained the general mathematical expression of the curve of equilibrium for different types of loads (defined by the curves of intrados and extrados), with a view to its application in Bridge analysis. His use of a simple parabolic load is remarkable for its simplicity and applicability in most cases.
 5. For the first time he considered the influence on the stability of the arch of a point load placed anywhere on the extrados. He devised a completely original method of obtaining the corresponding curve of equilibrium transforming that of the dead load.
 6. He had clear ideas of the transformation of curves of equilibrium (i.e. the affinity between them) and knew, for example, that the thrust, for a certain load distribution, is inversely proportional to the height of the curve, that the relative vertical distances remain constant, etc.
 7. Young's theory of the arch, based on a correct application of the approach of the equilibrium with due respect to the material properties, was well ahead of his contemporaries. The analysis of unsymmetrical arches were made only in the second half of the XIXth century. It apparently had no influence in later writers.
 8. Young's analysis of Telford's design is completely correct, combining statements of equilibrium (curves of equilibrium for the given loads) with statements about the material (cast iron must work in compression; therefore the curve of equilibrium must lie within the arch). The notion of a geometrical factor of safety is implicit in many of his statements.
 9. Young's approach is within the frame of modern limit analysis and of the Fundamental Safe Theorem. The main corollary of this Theorem is the "approach of equilibrium" and this is precisely the procedure of Young, which he followed with deep understanding.
 10. Telford's design, with some modifications, would have been a completely safe structure. Would it have been built, it will be today a symbol of London, in the same way as the Eiffel tower is a symbol of Paris. It is to regret that ignorance, fear and parsimony stopped Telford's grand design.

Appendix

Questions respecting the construction of a cast iron Bridge, of a single arch, 600 feet in the span, and 65 feet rise.

- I. What parts of the bridge should be considered as wedges, which act on each other by gravity and pressure, and what parts as weight, acting by gravity only, similar to

- the walls and other loading, usually erected upon the arches of stone bridges? Or does the whole act as one frame of iron, which can only be destroyed by crushing its parts?
- II. Whether the strength of the arch is affected, and in what manner, by the proposed increase of its width towards the two extremities or abutments, when considered vertically and horizontally? And if so, what form should the bridge gradually acquire?
 - III. In what proportion should the weight be distributed from the centre to the abutments, to make the arch uniformly strong?
 - IV. What pressure will each part of the bridge receive, supposing it divided into any given number of equal sections, the weight of the middle section being given? And on what parts, and with what force, will the whole act upon the abutments?
 - V. What additional weight will the bridge sustain, and what will be the effect of a given weight placed upon any of the before-mentioned sections?
 - VI. Supposing the bridge executed in the best manner, What horizontal force will it require, when applied to any particular part, to overturn it, or press it out of the vertical plane?
 - VII. Supposing the span of the arch to remain the same, and to spring ten feet lower, What additional strength would it give the bridge? Or, making the strength the same, What saving may be made of the materials? Or, if, instead of a circular arch, as in the plates and drawings, the bridge should be made in the form of an elliptical arch, What would be the difference in effect, as to strength, duration, convenience, and expenses?
 - VIII. Is it necessary or advisable, to have a model made of the proposed bridge, or any part of it, in cast iron? If so, what are the objects to which the experiments should be directed; to the equilibration only, or to the cohesion of the several parts, or to both united, as they will occur in the intended bridge?
 - IX. Of what size ought the model to be made, and what relative proportions will experiments, made on the model, bear to the bridge when executed?
 - X. By what means may ships be best directed in the middle stream, or prevented from driving to the side, and striking the arch; and what would be the consequence of such a stroke?
 - XI. The weight and lateral pressure of the bridge being given, can abutments be made in the proposed situation for London Bridge, to resist that pressure?
 - XII. The weight and lateral pressure of the bridge being given, can a centre or scaffolding be erected over the river sufficient to carry the arch without obstructing the vessels which at present navigate that part?
 - XIII. Whether would it be most advisable to make the bridge of cast and wrought iron combined, or of cast iron only? And if of the latter, Whether of the hard white metal, or of the soft grey metal, or of gun metal?
 - XIV. Of what dimensions ought the several members of the iron work to be, to give the bridge sufficient strength?

- XV. Can frames of cast iron be made sufficiently correct to compose an arch of the form and dimensions shown in the drawings, so as to take an equal bearing as one frame, the several parts being connected by diagonal braces, and joined by an iron cement, or other substance?
- XVI. Instead of casting the ribs in frames of considerable length and breadth, would it be more advisable to cast each member of the ribs in separate pieces of considerable lengths, connecting them together by diagonal braces, both horizontally and vertically?
- XVII. Can an iron cement be made, which shall become hard and durable, or can liquid iron be poured into the joints?
- XVIII. Would lead be better to use in the whole or any part of the joints?
- XIX. Can any improvements be made in the plan, so as to render it more substantial and durable, and less expensive; And if so, what are these improvements?
- XX. Upon considering the whole circumstances of the case, agreeable to the Resolutions of the Committee, as stated at the conclusion of their Third Report, is it your opinion that an arch of 600 feet in the span, as expressed in the drawings produced by Messrs. Telford and Douglas, or the same plan, with any improvement you may be so good as to point out, is practicable and advisable, and capable of being made a durable edifice?
- XXI. Does the estimate, communicated herewith, according to your judgement, greatly exceed or fall short of the probable expense of executing the plan proposed: specifying the general grounds of your opinion?

Acknowledgements

This article is a revised and expanded version of the draft of the Keynote Lecture of the same title delivered at the *4th International Conference on Arch Bridges* (Barcelona, November 17th–19th, 2004), by invitation of Prof. Pere Roca. The death of my mother impeded me to complete the draft in time to be included in the Proceedings. This paper is dedicated to her memory.

Notes

1. Though the project was signed by Telford and Douglass the credit for the design should be given to Telford. Ruddock (1979, 158) affirms that "... all the records convey the impression that he himself made the designs and estimates for London Bridge and that he conducted most of the subsequent investigations and negotiations". For Skempton (1980, 67) "... Douglass, though a clever and ambitious engineer. . . , had no experience and probably little knowledge of bridges".
2. The list, as it appears in the Fourth Report, is: Dr. Nevil Maskelyne (the Astronomer Royal), Rev. A. Robertson (Savilian Professor of Geometry, Oxford), Playfair (Professor of Mathematics, Edinburgh), John Robison (Professor of Natural Philosophy, Edinburgh), Dr. Milner, Dr. Charles Hutton (Royal Military Academy, Woolwich), Mr.

- Atwood, Colonel Twiss (Woolwich), Mr. William Jessop, Mr. J. Rennie, Mr. James Watt, Mr. John Southern, Mr. William Reynolds, Mr. John Wilkinson, Mr. Charles Bage, General Bentham (Inspector General of the Naval Works of the Admiralty), and Mr T. Wilson.
3. Young considered the article "Bridge" one of his major contributions to the Encyclopaedia Britannica. This is already evident in his correspondence with the editor Napier (Wood and Oldham 1954, 259). But in the list of the 62 articles written for the Encyclopaedia which he included in the catalogue of works of his own autobiography, only three appear in capital letters, Bridge, Egypt and Tides (Hilts 1978, 259), as a sign of their importance.
 4. The exposition is very similar to the most important paper of Moseley (1838) on the subject. Moseley formulated all his theory of lines of thrusts (*lines of resistances*) as if there was no precedent. He should have been aware of Young's work.
 5. The application of affine transformations to the study of the equilibrium of arches is a powerful tool, which was exploited extensively by Rankine (1858). For a historical study of this approach see Huerta (2004, 407).
 6. At the beginning of the XXth century several masonry bridges of more than 300 feet were built; the greatest, in unreinforced concrete, at Cruseilles, 1928, with 140 m or 450 feet. (Huerta 2004, 407).

Bibliography

- Atwood, G. 1801. *A Dissertation on the Construction and Properties of Arches*. London: Bulmer.
- Atwood, G. 1804. *A Supplement to a Tract, entitled a Treatise on the Construction and Properties of Arches*. London: Bulmer.
- Audoy. 1820. Mémoire sur la poussée des voûtes en berceau. *Mémorial de l'Officier du Génie*. 4: 1–96.
- Becchi, Antonio and Federico Focè. 2002. *Degli Archi e delle volte. Arte del costruire tra meccanica e stereotomia*. Venezia: Marsilio.
- Bélidor, B.F. 1729. *La science des ingénieurs dans la conduite des travaux de fortification et architecture civile*. Paris: Jombert.
- Boistard, L.C. 1810. Expériences sur la stabilité des voûtes. *Recueil de divers mémoires extraits de la bibliothèque impériale des ponts et chaussées à l'usage de MM. les ingénieurs*, edited by P. Lesage, 2: 171–217, Pls. 11–16. Paris: Chez Firmin Didot.
- Charlton, T. M. 1982. *A history of theory of structures in the nineteenth century*. Cambridge: Cambridge University Press.
- Coulomb, C. A. 1773. Essai sur une application des règles de maximis et minimis à quelques problèmes de statique relatifs à l'architecture. *Mémoires de Mathématique et de Physique, présentés à l'Académie Royale des Sciences par Divers Savants et lus dans ses Assemblées (Paris)*. 7: 343–382.
- Couplet, P. 1730. Seconde partie de l'examen de la poussée des voûtes. *Mémoires de l'Académie Royale des Sciences Paris*. 117–141, Pl. 6–7.

- Danyzy, A. A. H. 1732. Méthode générale pour déterminer la résistance qu'il faut opposer à la poussée des voûtes. *Histoire de la Société Royale des Sciences établie à Montpellier, 1718–45*. 2: 40–56. (Montpellier: Jean Martel, 1778.)
- Dorn, Harold I. 1970. *The Art of Building and the Science of Mechanics. A Study of the Union of Theory and Practice in the Early History of Structural Analysis in England*. Ph.D. diss.: Princeton University.
- Emerson, William. 1754. *The principles of mechanics*. London: W. Ynnys, J. Richardson. .
- Fourth Report. 1801. Fourth report from the Select Committee upon the Improvement of the Port of London (3rd. June 1801). *Reports of committees of the House of Commons 1715–1801*. 14: 604–635.
- Gauthey, Emiland-Marie. 1809-1813. *Traité de la construction des ponts*. Publié par M. Navier. Paris: Firmin Didot.
- Gurney, Hudson. 1831. *Memoir of the life of Thomas Young, M. D., F. R. S. with a catalog of his works and essays*. London: John and Arthur Arch, Cornhill.
- Hertwig, A. 1941. Die Entwicklung der Statik der Baukonstruktionen im 19. Jahrhundert. *Technikgeschichte*. 30: 82–98.
- Heyman, J. 1972. *Coulomb's Memoir on Statics: An Essay in the History of Civil Engineering*. Cambridge: Cambridge University Press.
- Heyman, J. 1982. *The Masonry Arch*. Chichester: Ellis Horwood.
- Heyman, J. 1995. *The stone skeleton. Structural engineering of masonry architecture*. Cambridge. Cambridge: Cambridge University Press. (Spanish translation: *El esqueleto de piedra. Mecánica de la arquitectura de fábrica*. Madrid: Instituto Juan de Herrera, 1999.)
- Heyman, J. 1998. *Structural analysis: a historical approach*. Cambridge: Cambridge University Press. (Spanish translation: *Análisis de estructuras. Un estudio histórico*. Madrid: Instituto Juan de Herrera, 2004.)
- Hilts, V. L. 1978. Thomas Young's 'Autobiographical sketch'. *Proceedings of the American Philosophical Society*. 122: 248–260.
- Hooke, R. 1676 [sic 1675]. *A description of helioscopes, and some other instruments*. London.
- Huerta, S. 2004. *Arcos, bóvedas y cúpulas. Geometría y equilibrio en el cálculo tradicional de estructuras de fábrica*. Madrid: Instituto Juan de Herrera.
- Hutton, Ch. 1772. *The Principles of Bridges*. Newcastle: Kincaird and Creech.
- Hutton, Ch. 1812. *Tracts on mathematical and philosophical subjects comprising, among numerous important articles, the Theory of Bridges*. London: Wilkie and Robinson.
- Kurrer, K.-E. 1997. Zur Entwicklungsgeschichte der Gewölbetheorien von Leonardo da Vinci bis ins 20. Jahrhundert. *Architectura*, 27: 87–114.
- La Hire, Ph. de. 1712. Sur la construction des voûtes dans les édifices. *Mémoires de l'Académie Royale des Sciences de Paris*. 70–78.
- Mairle, L. 1933 [printed 1935]. *Die Entwicklung der Berechnung statisch unbestimmter massiver Bogen und Gewölben unter dem Einfluß der Elastizitätstheorie*. Diss. Technischen Hochschule Carolo-Wilhelmina zu Braunschweig.

- Méry, E. 1840. Mémoire sur l'équilibre des voûtes en berceau. *Annales des Ponts et Chaussées*. 50–70, Pl. 133–134.
- Moseley, H. 1835. On the equilibrium of the arch. (Read Dec. 9, 1833). *Cambridge Philosophical Transactions*. 5: 293–313.
- Moseley, H. 1838. On the theory of the equilibrium of a system of bodies in contact. *Cambridge Philosophical Transactions*. 6: 463–491.
- Peacock, G. 1855. *Life of Thomas Young*. London: John Murray. (Reprint: Bristol, Thoemmes Press, 2003.)
- Poncelet, J. V. 1852. Examen critique et historique des principales théories ou solutions concernant l'équilibre des voûtes. *Comptes-rendus de l'Académie des Sciences (Paris)*. 35, n° 17: 494–502, 531–540, 577–587.
- Rankine, W. J. M. 1858. *A Manual of Applied Mechanics*. London: Charles Griffin.
- Rickman, J. Ed. 1838. *Life of Thomas Telford, Civil engineer, written by himself: containing a decriptive narrative of his professional labours*. London: Payne and Foss. .
- Robison, J. 1801. Arch. *Supplement to the third edition of the Encyclopaedia Britannica*. Edinburgh: Thomson Bonar. Republished in: *A System of Mechanical Philosophy*. Edinburgh: John Murray, 1822, 1: 616–60.
- Ruddock, T. 1979. *Arch Bridges and Their Builders, 1735–1835*. Cambridge: Cambridge University Press.
- Skempton, A. W. 1980. Telford and the design for a new London Bridge. In: *Thomas Telford: Engineer*, edited by A. Penfold, 62–83. London: Ironbridge Gorge Museum Trust.
- Some Account. 1811. Some Account of the different Theories of Arches or Vaults, and of Domes, and of the Authors who have written on this most delicate and important Application of Mathematical Science. *Philosophical Magazine*. 38: 387–91, 409–20.
- Southern, J. 1801. On the equilibrium of arches. *Philosophical Magazine*. 11: 97–107.
- Straub, H. 1952. *A History of Civil Engineering*. London : Leonard Hill.
- Telford, Th. 1801. An Account of the Improvements of the Port of London and More Particularly of the Intended Iron Bridge Consisting of One Arch Six Hundred Feet Span. *Philosophical Magazine*. 10: 59–67.
- Third Report. 1800. Third report from the Select Committee upon the Improvement of the Port of London (28th. July 1800, with Appendixes). *Reports of committees of the House of Commons 1715–1801*. 14: 604–635.
- Timoshenko, S. P. 1953. *History of Stregnth of Materials*. New York: McGraw-Hill.
- Todhunter, I. y K. Pearson. 1960 (1a. ed. 1886). *A history of the theory of elasticity and of the strength of materials from Galilei to Lord Kelvin*. New York: Dover.
- Winkler, E. 1879 and 1880. Die Lage der Stützlinie im Gewölbe. *Deutsche Bauzeitung*. 13: 117– 119, 127–128, 130; and 14: 58– 60.
- Wood, A. and F. Oldham. 1954. *Thomas Young. Nätural philosopher; 1773-1829*. Cambridge: Cambridge University Press, 1954.
- Young, Th. 1807. *A Course of Lectures on Natural Philosophy and the Mechanical Arts*. London: Joseph Johnson. (Reprint: Bristol, Thoemmes Press, 2002.)

- Young, Th. 1807. Remarks on the Structure of covered Ways, independent of the Principle of the Arch in Equilibrium, and on the Best Forms for Arches in Buildings. *A Journal of Natural Philosophy, Chemistry and the Arts*. 18: 241–250. Republished in: *Miscellaneous Works*, edited by G. Peacock, 2: 179–189. London: John Murray, 1855.
- Young, Th. 1824 (1817). Bridge. In: *Supplement to the fourth, fifth and sixth editions of the Encyclopaedia Britannica*, 2: 497–520, pls. 42–44. Edinburgh: Archibald Constable. Republished in part in: *Miscellaneous Works*, edited by G. Peacock, 2: 194–247. London: John Murray, 1855.
- Young, Th. *Miscellaneous Works of the late Thomas Young*, edited by G. Peacock. London: John Murray. (Reprint: Bristol, Thoemmes Press, 2003.)

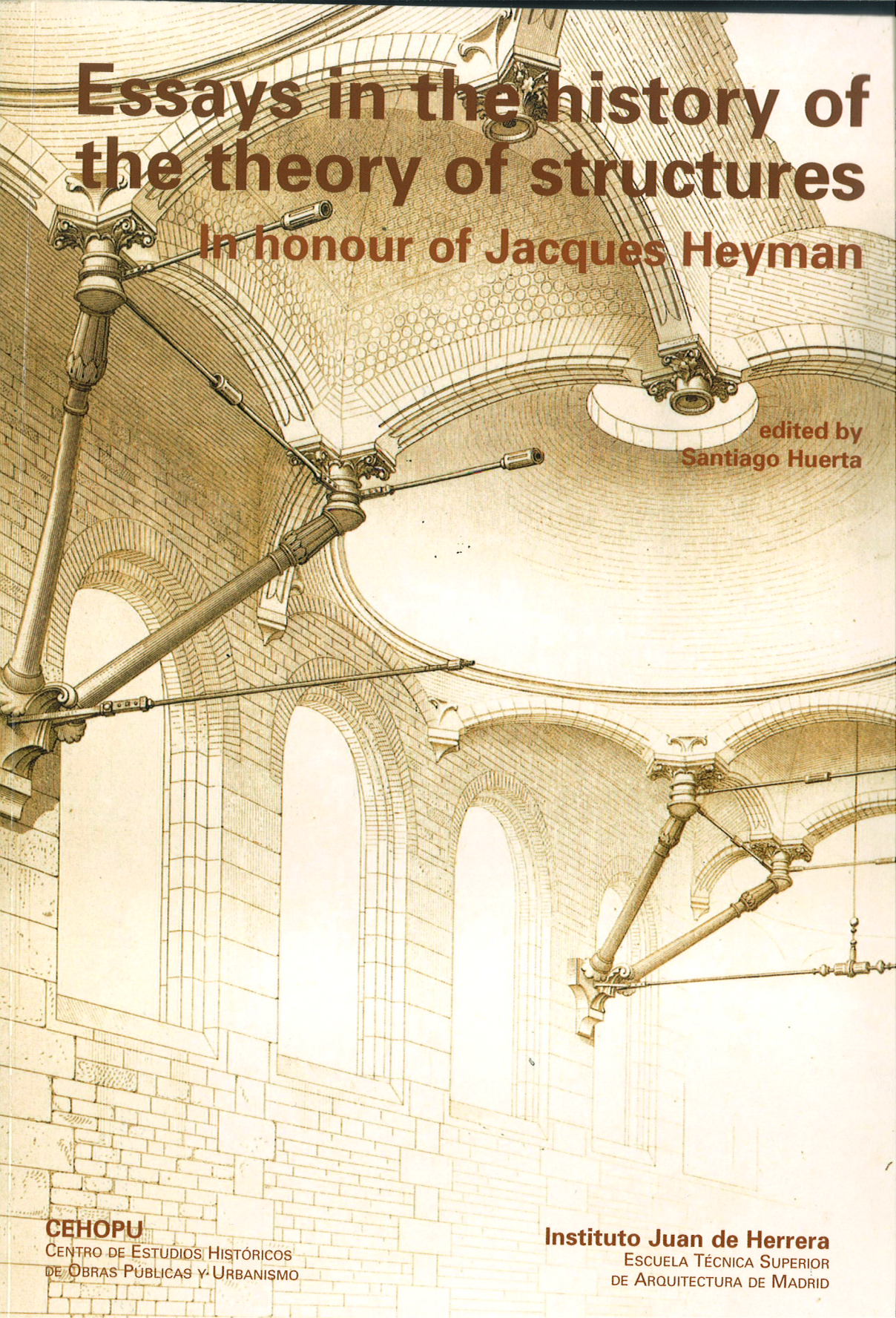

Essays in the history of the theory of structures

In honour of Jacques Heyman

edited by
Santiago Huerta

CEHOPU

CENTRO DE ESTUDIOS HISTÓRICOS
DE OBRAS PÚBLICAS Y URBANISMO

Instituto Juan de Herrera

ESCUELA TÉCNICA SUPERIOR
DE ARQUITECTURA DE MADRID

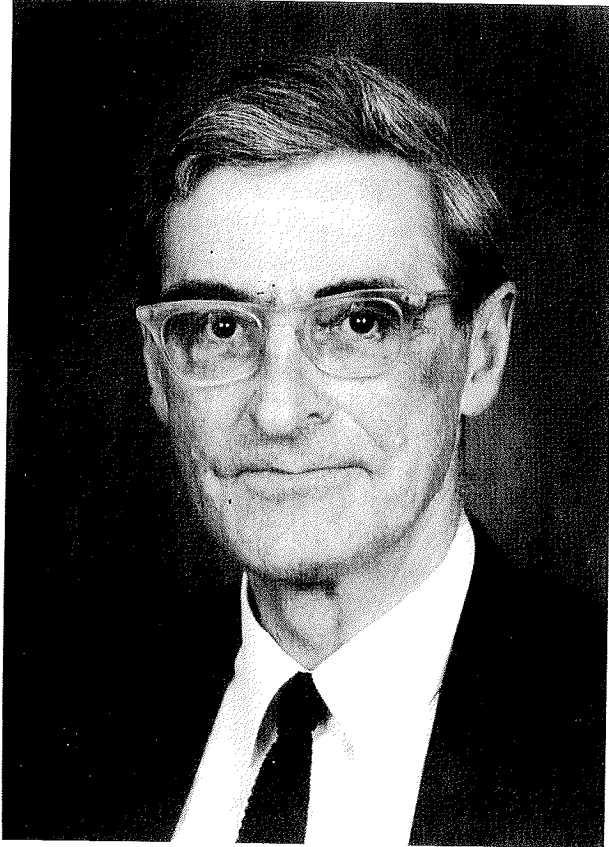

Professor Jacques Heyman

Essays in the history of the theory of structures

In honour of Jacques Heyman

Edited by
Santiago Huerta

Foreword by
Ricardo Aroca Hernández-Ros

Introduction by
Santiago Huerta

CEHOPU
Centro de Estudios Históricos de Obras Públicas y Urbanismo

CEDEX
Centro de Estudios y Experimentación de Obras Públicas
Ministerio de Fomento

INSTITUTO JUAN DE HERRERA
Escuela Técnica Superior de Arquitectura
Madrid

Diseño de la portada: Ignacio Gil Crespo

De la presente edición:

© Instituto Juan de Herrera, 2005

© Ministerio de Fomento. CEDEX-CEHOPU, 2005

Todos los derechos reservados

NIPO: 163-05-020-0

ISBN: 84-7790-416-2 (Tapa dura)

ISBN: 84-7790-418-9 (Rústica)

Depósito Legal: M. 46.774-2005

Cubierta: Dibujo tomado de: E. E. Viollet-le-Duc *Entretiens sur l'architecture*. París: 1863

Fotocomposición e impresión: EFCA

Contents

Foreword by <i>Ricardo Aroca Hernández-Ros</i>	ix
Acknowledgements	xi
Introduction by <i>Santiago Huerta</i>	xiii
Publications of Jacques Heyman	xvii
The history of the theory of structures	
<i>Jacques Heyman</i>	1
A history of using models to inform the design of structures	
<i>Bill Addis</i>	9
Vaults in the air: <i>Signor Fabritio's</i> English theory	
<i>Antonio Becchi</i>	45
Analysis of continuous prestressed concrete beams	
<i>Christopher J. Burgoyne</i>	61
Preliminary structural analysis of a Guastávino spiral staircase shell	
<i>Christopher R. Calladine</i>	79
The mechanical sciences in Antiquity	
<i>Massimo Corradi</i>	103
On the safety of the masonry arch. Different formulations from the history of structural mechanics	
<i>Federico Focè</i>	117
Nondeterministic structural analyses: Insights on atatic behaviour of hyperstatic structures	
<i>Dario Gasparini and Stephen G. Buonopane</i>	143
New lamps for old – Should computers provide engineers with answers or help us think?	
<i>Bill Harvey</i>	179
Thomas Young's theory of the arch: His analysis of Telford's design for an arch of 600 feet span	
<i>Santiago Huerta</i>	189
Grace and law: The spatial framework from Föppl to Mengerinhausen	
<i>Karl-Eugen Kurrer</i>	235

- Boscovich's contribution to the theory of domes: the expertise for the
Tiburio of Milan cathedral
Gema López Manzanares 273
- Towards equilibrium in Finite Element Analysis
Edward A. W. Maunder 303
- Analysis of flat concrete slabs on columns
Christopher T. Morley 327
- Practice Before Theory: The Use of the Lower Bound Theorem in structural
design from 1850 to 1950
John A. Ochsendorf 353
- Theory, industry and practice: Carnegie's Pocket Companion and the
development of skyscraper construction in Chicago
Tom F. Peters 367
- Gustave Magnel (1889-1955), a scientific biography
Patricia Radelet-de Grave 389
- Non-smooth formulation for the ancient and strongly non-linear problem
of block dynamics
Anna Sinopoli and Alessio Agno 429
- List of contributors 453